

engineer's notebook

Soil Pressure under Footings

Aids for the structural engineer's toolbox...

What is the soil pressure under a spread footing when, or if, a moment is applied to the footing with the axial load on the footing?

To use the curves, the eccentricity "e" of the resultant vertical force "P" is found for the applied loads and forces and the value of e/d for the footing is established. The curve for the desired footing is entered with the value e/d and the values "C" and "k" for that e/d are determined. The value "C" is used to establish the soil pressure for that size and shape footing. If "C" is less than 2.00, there is no uplift of the end of the footing away from the soil; if "C" is greater than 2.00, the "k" indicates the percentage of the footing length still in bearing with the soil.

Designers using this information should keep in mind that the vertical load "P" includes the weight of the footing, soil over the footing, and any other loads (concrete slab, live load, etc.) which may be over the footing; these loads normally would pass through the footing into the soil below without any structural impact on the footing. However, if the minimum soil pressure unit stress under overturning forces (f₂) is less than the total unit weight of the

footing and any loads above the footing, those normally inert unit loads will overcome the soil pressure reaction and develop moments in the footing which will require reinforcing steel in the top of the footing.

If, or when, loads develop footing uplift from the soil (f₂ = 0) many engineers would not accept a value of "k" less than 85% before changing the size of the footing. The actual acceptable value of "k" may be an engineering judgment based on the cause of the overturning moment. For a moment of short duration, as from wind, a lower value of "k" may be acceptable when compared to a moment of long duration, such as from operating machinery. Remember, the term "C" in the formula is applied to the average soil pressure P/A without overturning moment. If you are working with an average soil pressure of 3,000 psf, a "k" of 0.85 would develop a maximum soil pressure of over 10,000 psf.

The Cases shown Indicated is the mathematical method to determine the values of "C" and "k" for the curve. Similar methods are used to develop those val-

ues for circular and octagonal footings.

The sources used above to establish the shape, size, and soil pressure are service loads. The remaining structural design of the footing will require conversion of the service loads into factored loads. The same basic technique is again used to determine the footing factored soil pressure under the factored loads. Typical procedures are then employed to establish moments for longitudinal reinforcing steel and to check for acceptable shear values in the footing. ■

Provided by:

Allen H. Seckinger, P.E.,
Semi-retired, Tampa, FL
Fellow, Life Member, ASCE

This shorthand method is a variation that is given in various textbooks.

Bearing pressure determination for square or rectangular footings.

Limitations:

1. Forces and moments must occur at center of footing in each direction.
2. Lateral load and applied moment are in one direction only.

Notation:

- P_a = Applied vertical load [column load]
- M_a = Applied moment at top of pier
- V_a = Applied shear at top of pier
- P = Total vertical reaction to soil
- M = Total overturning moment at base of footing
- A = Area of footing = bd
- S = Section modulus of footing about axis of bending
- b = Width of footing
- d = Length of footing
- e = Eccentricity of vertical reaction P
- f₁ = Maximum soil pressure
- f₂ = Minimum soil pressure
- h = Vertical distance from top of pier bottom of footing

$$\frac{bd^2}{6} = \frac{Ad}{6}$$

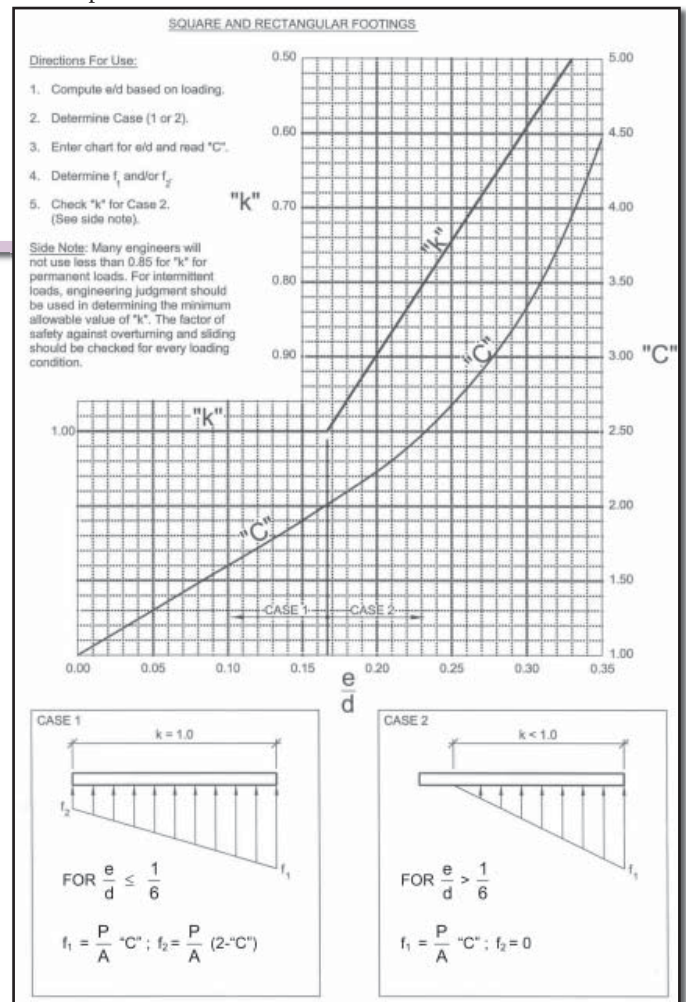

DERIVATION OF CASE 1

$$e < \frac{d}{6}$$

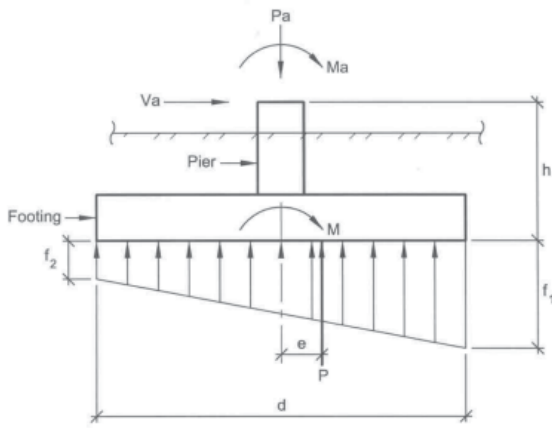

GOVERNING EQUATIONS FOR SOIL PRESSURE DISTRIBUTION (CASE 1)

$$f_1 = \frac{P}{A} + \frac{M}{S}; f_2 = \frac{P}{A} - \frac{M}{S}$$

$$P = Pa + [\text{weight of soil, footing, and pier}]$$

$$M = Ma + Va \cdot h = M = Pe$$

$$f_1 = \frac{P}{A} + \frac{6Pe}{Ad} = \frac{P}{A} \left(1 + \frac{6e}{d}\right) = \frac{P}{A} \text{ ("C" [CASE 1])}$$

$$f_2 = \frac{P}{A} \left(1 - \frac{6e}{d}\right) = \frac{P}{A} \text{ (2 - "C" [CASE 1])}$$

$$\text{"C" [CASE 1]} = \left(1 + \frac{6e}{d}\right)$$

DERIVATION OF CASE 2

$$e > \frac{d}{6}$$

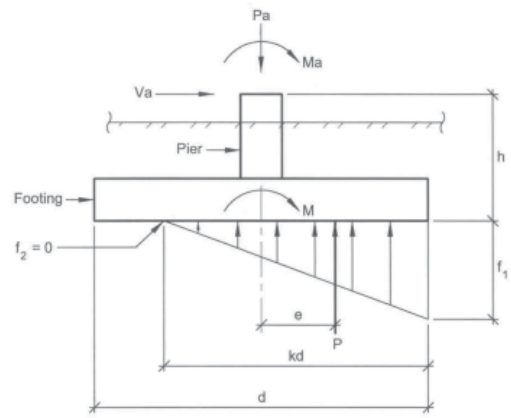

GOVERNING EQUATIONS FOR MAXIMUM SOIL PRESSURE (CASE 2)

$$f_1 = \frac{2P}{kdb} = \frac{2P}{kA} = \frac{P}{A} \left(\frac{2}{k}\right) = \frac{P}{A} \text{ ("C" [CASE 2])}$$

$$kd = 3 \left(\frac{d}{2} - e\right) \leftarrow \text{solve for } k$$

$$k = 1.5 - \frac{3e}{d}$$

$$\therefore \text{"C" [CASE 2]} = \left(\frac{2}{1.5 - \frac{3e}{d}}\right)$$

For Advertiser Information, visit HOT PRODUCTS at www.structuremag.org

ATLAS SYSTEMS, INC.®

Developer/Manufacturer of *Rapid Foundation™* Support Products and Equipment

"We Can Change History"™

SETTLEMENT?

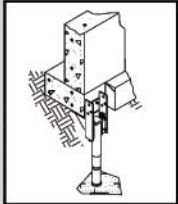

Restore with **Atlas Resistance® Piers** Resistance Products

SOIL PROBLEMS?

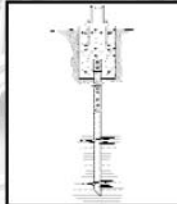

Support with **ATLAS Helical®** New Construction Products

LATERAL INSTABILITY?

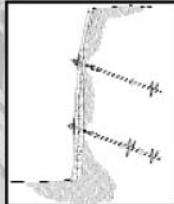

Support with **ATLAS Helical®** Tie-Back Products



MARKETS AVAILABLE:
For your local contractor or dealership inquiries, contact:
Atlas Systems, Inc.®
1026-B South Powell Road
Independence, MO 64056
Fax (816) 796-0919



1-800-325-9375

E-mail: info@atlassys.com

VISIT US AT: www.atlassys.com

GROUTING

Chemgrout systems offer you the World's widest selection of mixers, pumps and power options.



Call for complete details

1-708-354-7112

Visit our web site:
www.chemgrout.com

ChemGrout®