



Figure 1: M. Tower Single Pile per leg



Figure 2: Pile Installation

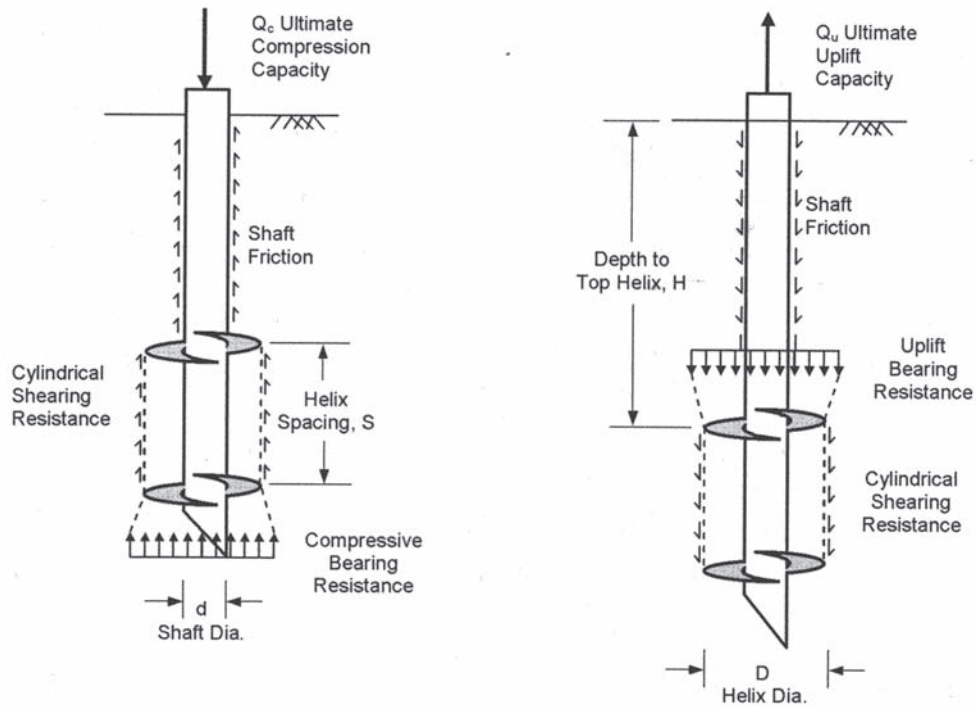

Figure 3: Screw Pile in Compression and Tension Loading

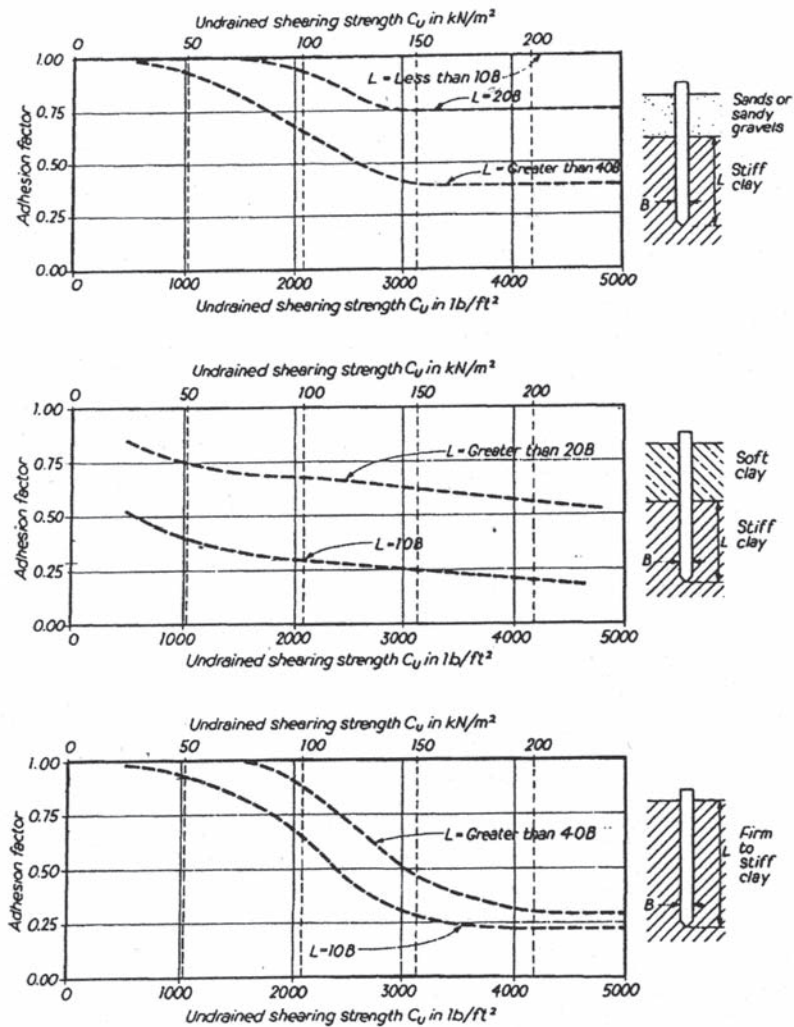

Figure 4: Design Curves for Adhesion Factors for Piles Driven into Clay Soils

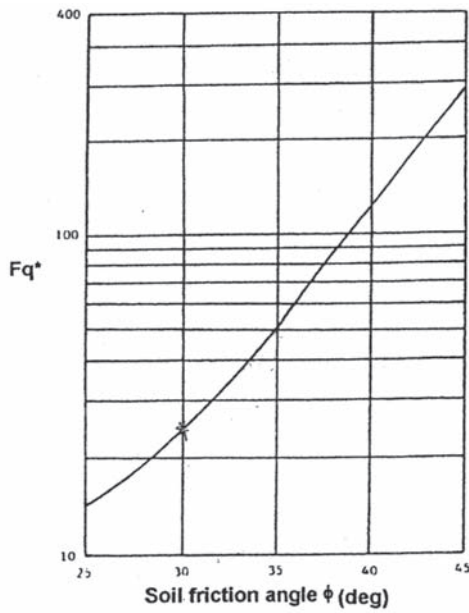

Figure 5: Variation of Breakout Factor with Embedment Depth for Deep Anchor

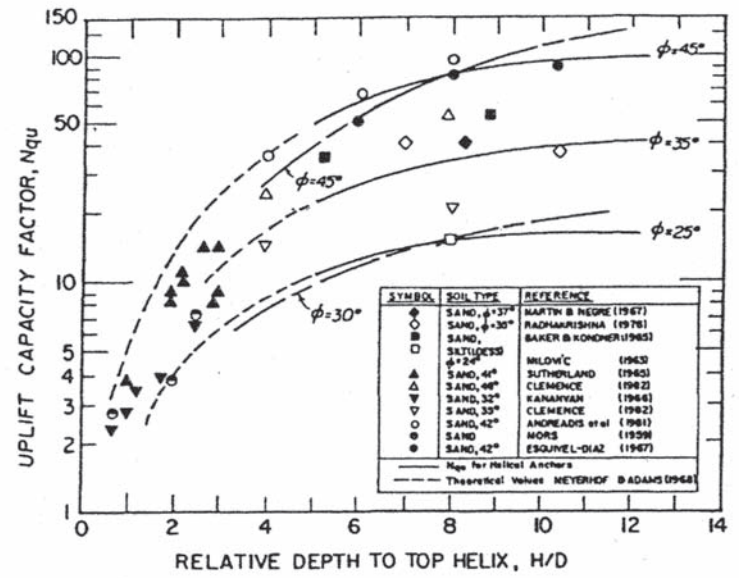

Figure 6: Uplift Capacity Factor, N_{qu} , vs. Embedment Ratio, H/D Ratio for Helical Anchors in Sand

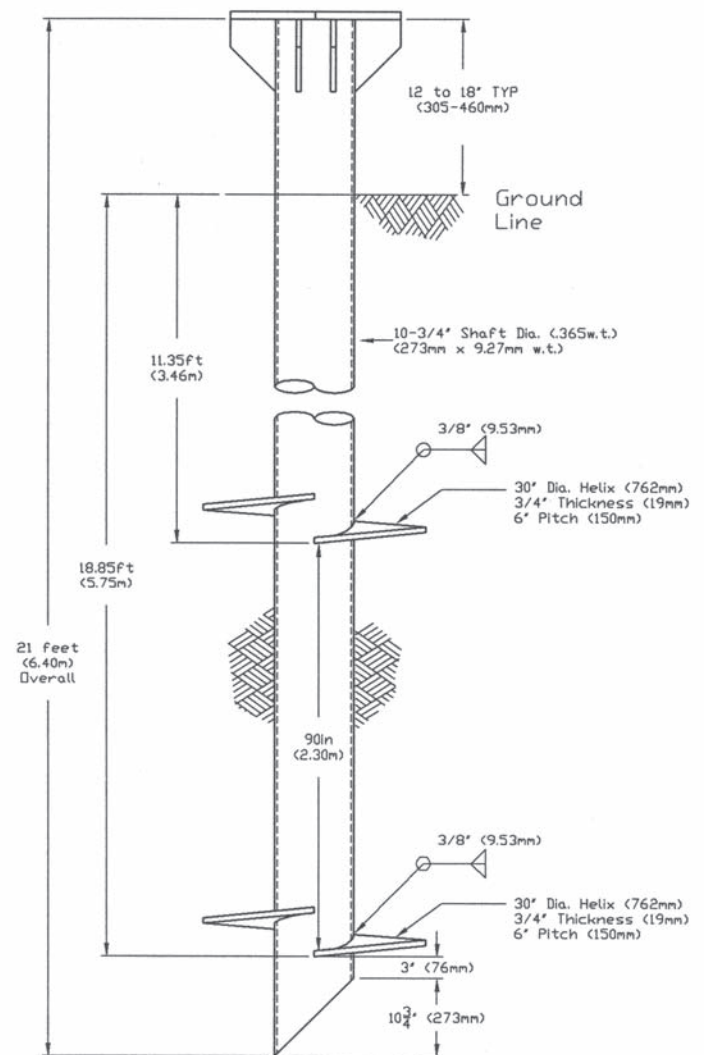
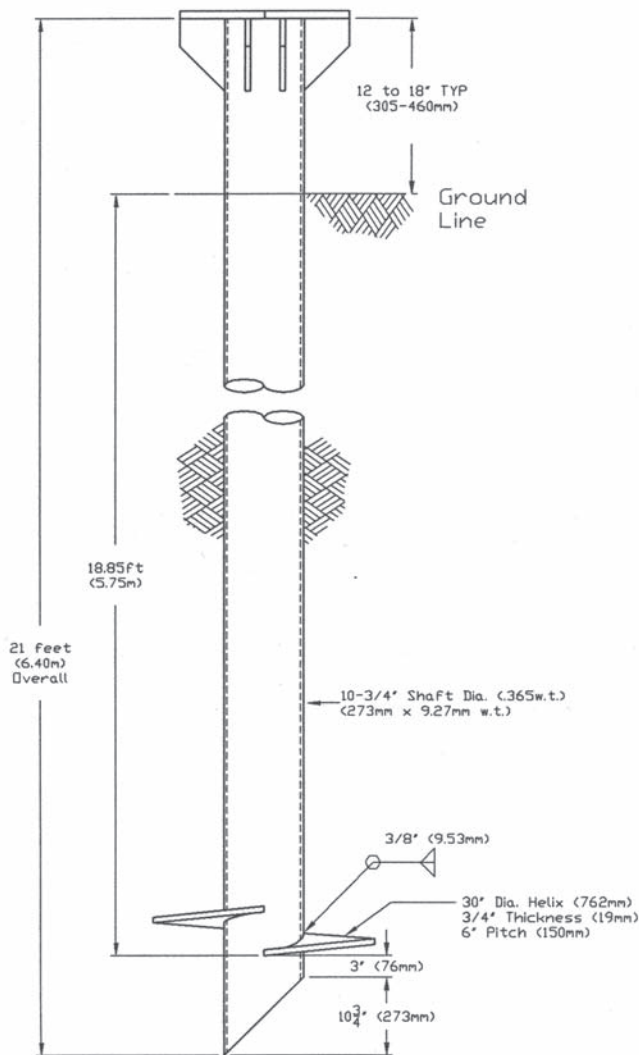

Figure 7: Compression and Tension Screw Piles

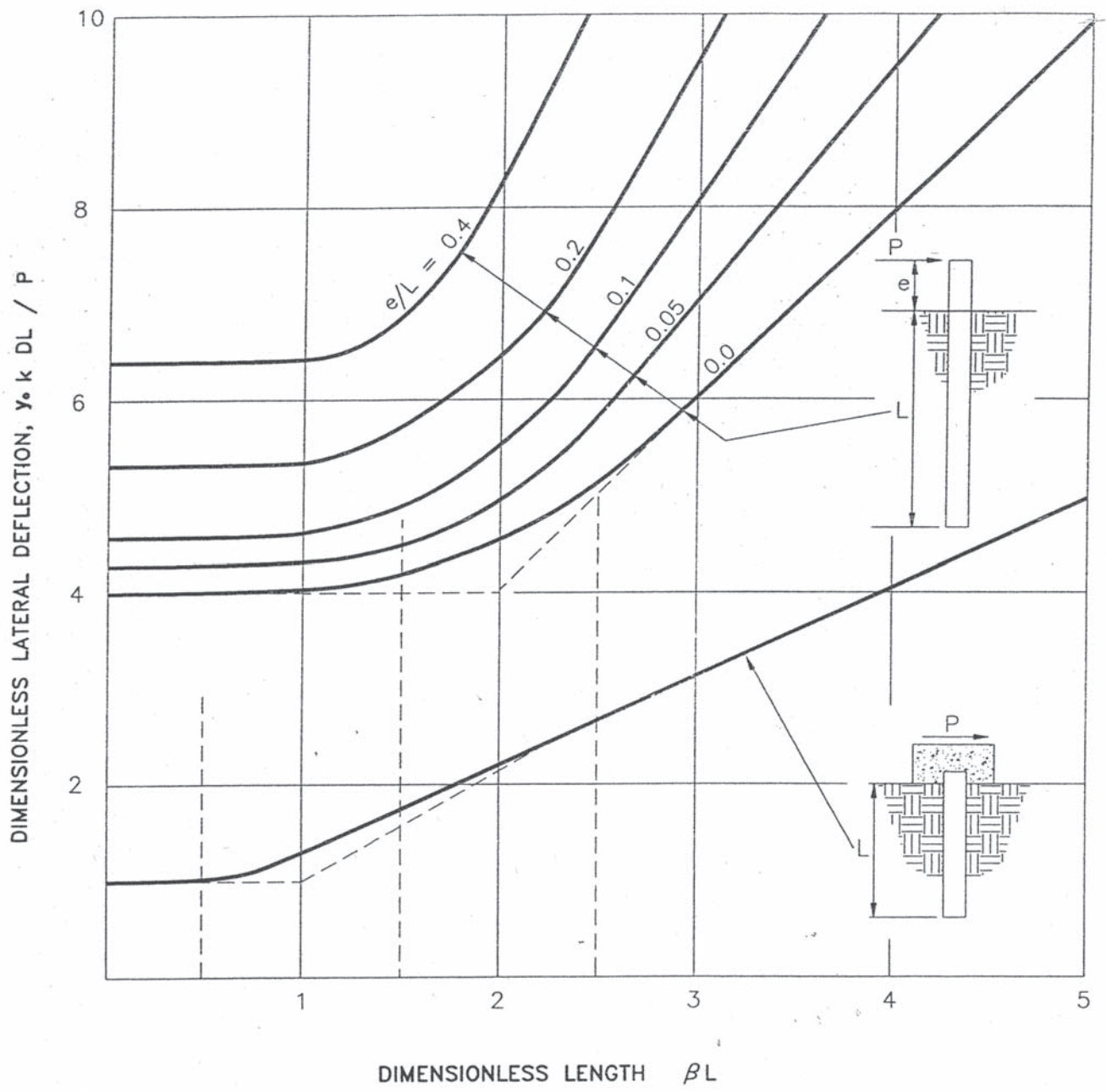

Figure 8