

Truss Bracing

Design Guidelines for Bracing of Cold-Formed Steel Trusses

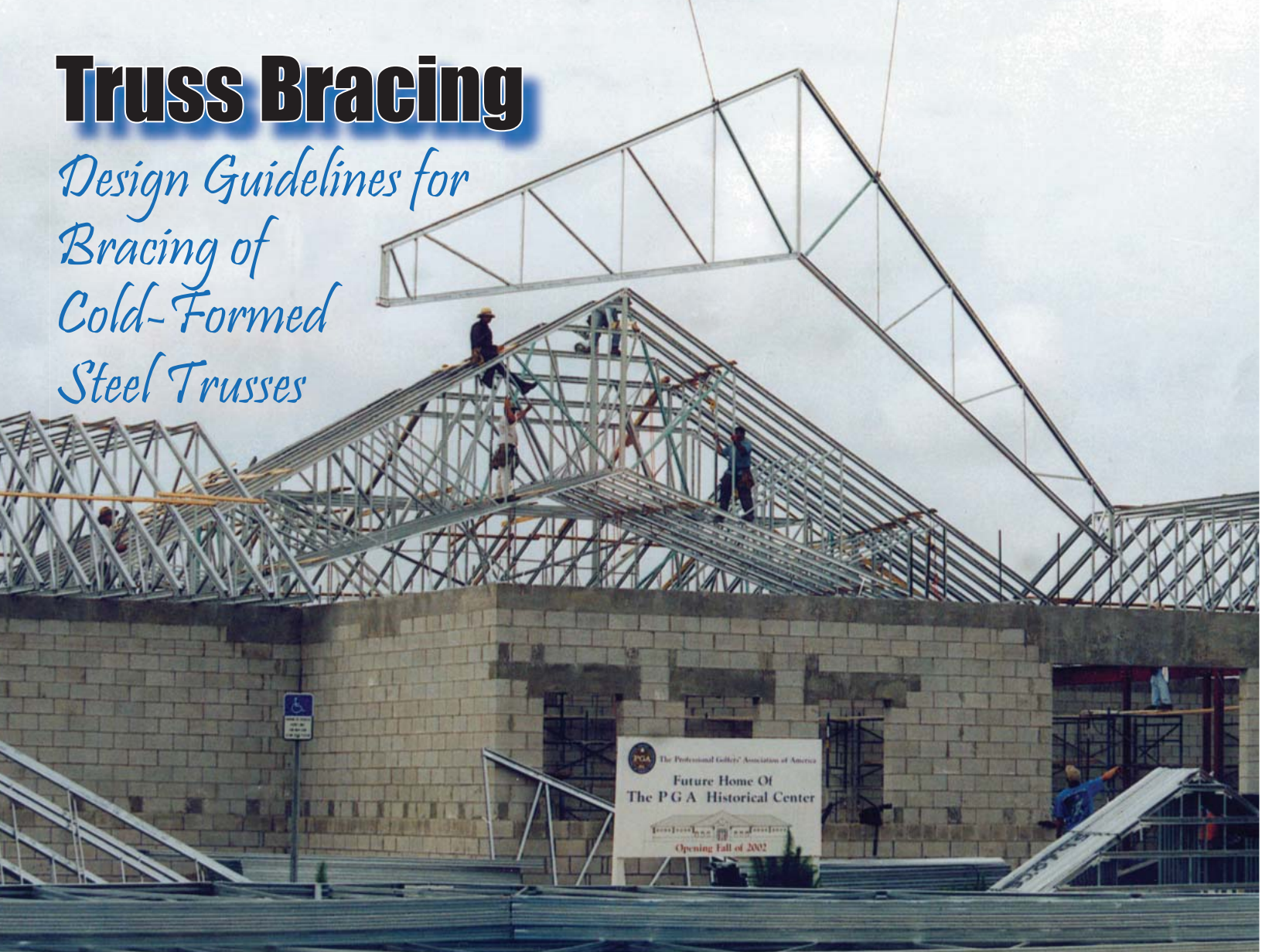

By: Bill Babich, P.E. and Don Allen, P.E.

Bracing of trusses and truss systems can be complex, and is often ignored by design professionals. Many engineers rely on component manufacturers to give guidance on bracing of truss systems, both steel and wood. The Light Gauge Steel Engineers Association (LGSEA), the Steel Truss and Component Association (STCA) and the American Iron and Steel Institute (AISI) have excellent resources available that give general guidelines. However, the engineer of record is ultimately responsible for the design of the structure, and therefore needs to confirm that the truss system bracing design has been adequately addressed.



Bill Babich, P.E., serves as Chief Engineer for the TrusSteel Division of Alpine Engineered Products, Inc., in Haines City, FL. Don Allen, P.E., serves as Executive Director of the Light Gauge Steel Engineers Association, headquartered in Washington, DC.



Top Chord Lateral Braces at Gable End

Why is Bracing Required?

There are several reasons for truss bracing in a roof or floor structure. During construction, before all of the components of a truss system are in place, bracing acts to hold members upright, straight, and in place. This “temporary bracing” typically may not be the responsibility of the structural engineer. However, contractor clients may hire the engineer or component manufacturer to design this temporary bracing, since it can be very costly and dangerous if improperly addressed.

“Specific types of bracing can often help redistribute the load...”

Truss bracing also acts to transfer loads to other parts of the structure that can better resist these loads. Often, a single truss or truss member cannot take certain loads by itself. Specific types of bracing can often help redistribute the load over multiple trusses or to stiffer supports if needed. For individual truss members, if the axial load is too high for a given slenderness, weak axis bracing can reduce the effective length and increase member capacity. Bottom chord bracing, even in conditions where the bottom chord remains in tension, can help ensure web member capacity is as the designer expected. If the bottom chord is left unbraced, axial compression in web members can produce a horizontal force at the bottom chord, especially with back-to-back (offset) web members. If this force is not braced, the effective K value for the compression web could be considered to be as much as 2, which may greatly reduce the load carrying capacity of the member. Bottom chord bracing is also required where wind uplift loads create bottom chord axial compression. Although

compression may not be the governing load condition, even small amounts of axial compression can result in failure of long, unbraced members. A good rule of thumb is to follow the bracing requirements found in the LGSEA Technical Note *Field Installation Guide for Cold-Formed Steel Roof Trusses*, or to brace the truss chords at each panel point.

Achieving Truss Bracing

There are two general categories of bracing: temporary bracing and permanent bracing.

Temporary bracing is covered in *LGSEA Tech Note 551d: Design Guide for Construction Bracing of Cold-Formed Steel Trusses*. It is the bracing placed in the trusses at the time of truss erection. Temporary bracing is often kept in the structure and allowed to double as permanent bracing. It may also be used to facilitate truss installation, by reinforcing the trusses against the different stresses induced during lifting or staging. Often, several trusses or even an entire section of roof or floor may be braced together and lifted in place. Temporary bracing may be used to help accomplish successful lifts. The *LGSEA Field Installation*

Guide for Cold-Formed Steel Roof Trusses also gives some guidance on temporary bracing configuration and location.

Permanent bracing is covered in *LGSEA Tech Note 551e: Design Guide for Permanent Bracing of Cold-Formed Steel Trusses*. This is bracing that is required to stay in the truss system for the life of the structure. Permanent bracing helps resist the long and short-term loading and load combinations specified in the building codes. Proper attention to the permanent bracing design will insure the structure will meet the demands placed upon it during its service life.

Sheathing is an important component of the roof truss permanent bracing system and must be designed to resist bracing loads. It is typically attached directly to the top of the top chord members, and is sometimes used as part of the roof or floor diaphragm. Sheathing braces the members that it is attached to, and helps distribute the bracing loads out to the building elements that resist lateral loads. Sheathing is the most efficient way to distribute these bracing forces.

Occasionally, sheathing is not attached directly to the truss members. Often, “Z” or “F” (furring) members are used where sheathing cannot span the distance between trusses. These furring members may be designed as bracing members. The designer must include both the bending loads induced by the sheathing, as well as the axial loads from the member brace force. With piggyback trusses, or overbuilt trusses or rafters, some portions of the top chord are not immediately adjacent to the roof deck or sheathing. Nonetheless, these chord members may experience high axial loads. The designer must ensure that sheathing, furring, or other members are used to brace truss chords below piggyback trusses and below overbuilt rafters, or design their top chords with longer unbraced lengths in these areas.

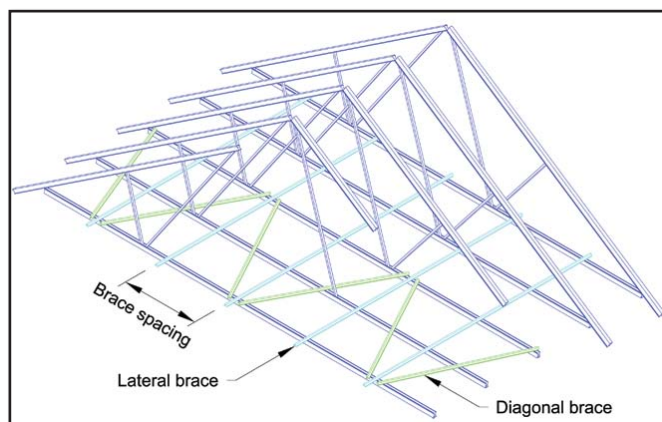

Figure 1 Truss System Bracing

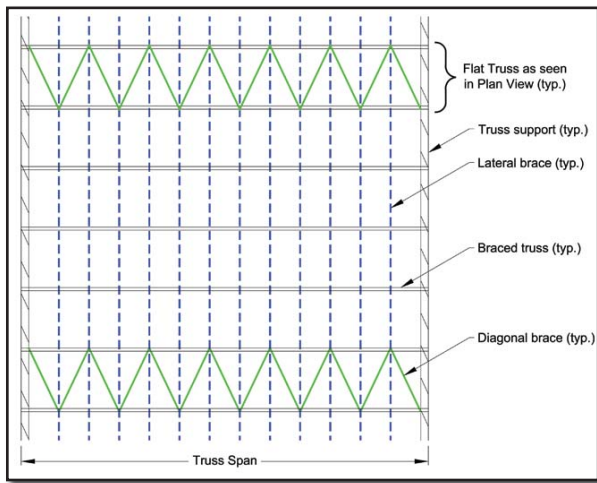

Figure 2 Lateral and Diagonal Bracing Layout

How to Brace Truss Systems

Entire manuals and chapters have been written on truss system bracing; here is an overview of some of the truss bracing options available to the designer.

LGSEA Technical Note 551g, due for publication in Fall 2004, provides additional guidance, equations, and a method for designing system bracing. This overview includes those factors that need to be taken into consideration. Refer to Figures 1, 2 and 3 for truss bracing details that show the various elements of a truss bracing system.

Lateral Braces are braces between chords or webs of adjacent trusses. These are typically placed perpendicular to the plane of the chord or web. With C-shaped, angle, or tube shaped web members, they can be attached directly to the flanges of adjacent truss members. Lining up the truss webs can make the bracing installer's job much easier.

Diagonal Braces are braces placed between lateral braces, in the same plane, and between chords and webs of trusses. Diagonal braces may also be termed as X-bracing or cross bracing, because of their appearance within the structure. As seen in plan, diagonal braces used at the chord plane act as a sort of "flat truss", transferring loads from the lateral braces to adjacent walls or adjacent drag struts. Individual chords of adjacent trusses may become a part of this diagonal brace flat truss system. If this is the case, these trusses must be designed for the added bracing loads, as well as the typical load combinations from applied loads. Diagonal braces used at the web plane act as sort of a chevron brace for the truss system, and transfer loads from the web lateral braces to the roof deck and bottom chord plane.

Bridging is a brace between the top chord of one truss to the bottom chord of an adjacent truss. Bridging may also extend from a location of web bracing to a roof or ceiling diaphragm (shown in *LGSEA Technical Note 551e* as Figure 2).

Blocking may be part of the truss bracing system, but it is more likely to be used to transfer lateral diaphragm loads from the sheathing or roof deck down to the shear wall or drag strut below. Blocking may be accomplished using diagonal straps (Figure 3a), using a brake shape (Figure 3b), or using an actual truss (Figure 3c) to transfer these loads. (see *Figures, page 29*)

Sway braces are bridging braces installed to avoid truss tipping. These are typically used as temporary construction bracing; follow guidelines of *Technical Note 551d* and *Field Installation Guide for Cold-Formed Steel Roof Trusses*.

Design of the individual braces can be daunting and complex, but the use of some simple guidelines can greatly ease the task. *Tech Note 551e* states, "The design should be performed using a minimum of 2 percent of the full member axial forces." There are various other sources that give guidelines and data for brace force design. It is the responsibility of the designer to determine which source to use and what assumptions are made about rigidity of supports and of the system. *Tech Note 551e* gives an excellent example of brace design.

Design Responsibility

A question that is still hotly debated is, "Who designs the bracing, and who is ultimately responsible?" As the building designer, the architect or engineer of record is responsible to see that the bracing is designed and installed properly. However, the appendix to the AISI truss design guide, as well as *Tech Note 551f Specifying Cold-Formed Steel Roof and Floor Trusses* and AISI's *Standard for Cold-Formed Steel Framing – Truss Design* spell out at least part of the responsibilities of the owner, building designer, and truss designer. All of the above references specify

that the building designer is responsible for the permanent truss bracing, and that the truss designer is responsible for defining the locations of required permanent truss member bracing.

"...engineer of record is responsible to see that the bracing is designed and installed properly."

There are some truss component and truss system fabricators that also provide products and services to facilitate truss system bracing. These manufacturers are able to provide truss system bracing design services, and may even have the ability to provide specific bracing products to ease the installation of truss bracing. This does not mean that their design is any better or worse than other designs; but it may be more efficient to get them involved in the bracing design process due to their vast knowledge of truss systems.

Some engineers (building designers) will include statements in their specifications that spell out bracing design responsibilities. Contractors and truss designers bidding on these documents must carefully read these requirements, to ensure that everyone is clear about who does what before bids are issued. The wording of the structural general notes, as well as the specifications, must be consistent and clear on bracing issues. Although it is the responsibility of the specialty engineer to ensure that the truss elements will not fail, ultimately it is still the building designer's responsibility to review the design and ensure it is compatible with the other elements of the structure.

For additional information on bracing design and design responsibility, the references are available in the on-line version of this article. Please visit www.structuremag.org. ■



Figure 2 Lateral and Diagonal Bracing Layout

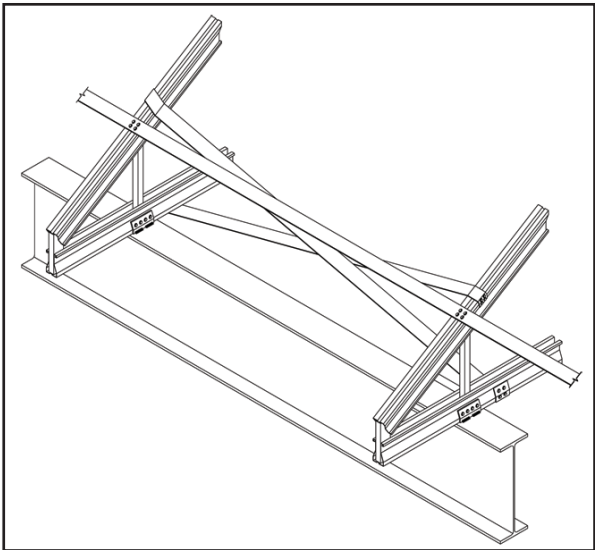

Figure 3a Straps as Blocking

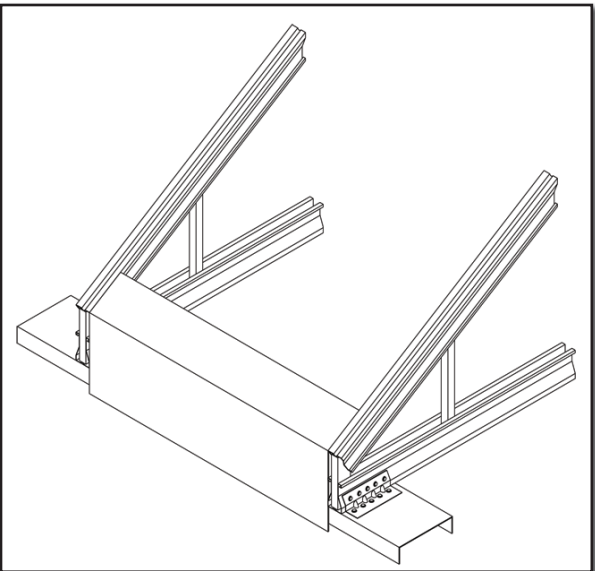

Figure 3b Cold-Formed Steel Brake Shape as Blocking

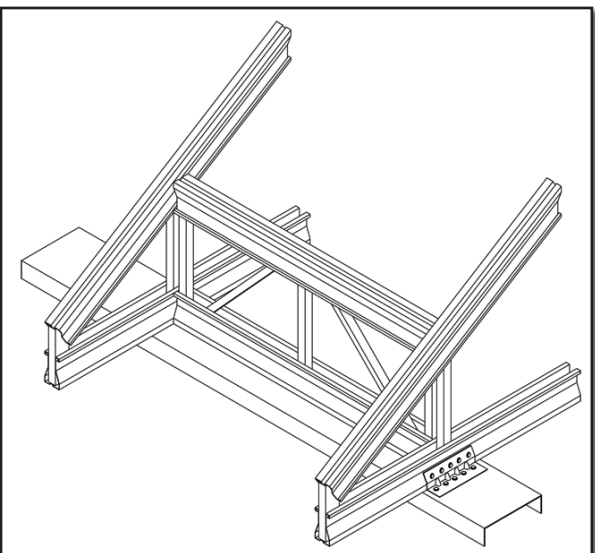

Figure 3c Truss as Blocking

For additional information on bracing design and design responsibility, the following references are available:

Standard for Cold-Formed Steel Framing – Truss Design, AISI/COFS/TRUSS 2001, American Iron and Steel Institute Committee on Framing Standards, www.steel.org

LGSEA Technical Notes on Cold-Formed Steel Framing, No.s 551f, 551e, 552g, and 551d, www.lgsea.com

Field Installation Guide for Cold-Formed Steel Roof Trusses, LGSEA, www.lgsea.com

Design Guide for Cold-Formed Steel Trusses (Publication RG-9518) American Iron and Steel Institute, 1995, www.steel.org

Specifications Guide for Cold-Formed Steel Trusses and Components, Steel Truss and Component Association (STCA), www.steeltruss.org

Jobsite Warning Poster for Cold-Formed Steel Trusses and Components, Steel Truss and Components Association (STCA), www.steeltruss.org

FIBERGLASS

A Step Above The Rest.

Flooring and Decking Products

- Corrosion Resistant
- Strong
- Lightweight
- Easy to Install
- Easy to Maintain
- Easily Transported

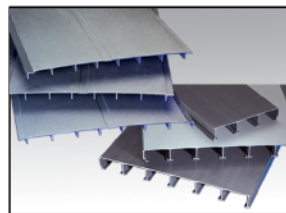

Replace wood, aluminum or steel in environments where corrosion or rotting creates costly maintenance problems or unsafe conditions.

Visit us online at www.strongwell.com

STRONGWELL
(276) 645-8000

For Advertiser Information, visit www.structuremag.org