

codes & standards

New Standards Available for Cold-Formed Steel Framing

Part 1: An Overview of Recent and Future AISI Design Standards

By Jay W. Larson, P.E., F.ASCE

Cold-formed steel framing is relatively new, and is developing rapidly compared to other construction materials. To hasten this rate of change, the American Iron and Steel Institute (AISI) helps turn state-of-the-art research into industry practice by serving as an ANSI-accredited standards development organization. In 2001, AISI completed four new ANSI-accredited design standards for the design of cold-formed steel framing (*Figure 1*). In 2004, several new documents will be released that provide additional information for designers, builders and code officials and further enable the widespread and economic use of steel framing in the United States.



Figure 1 AISI Standards for Cold-Formed Steel Framing

Background

The AISI has long had a role in standards development. Since the 1940's, AISI has engaged a committed group of professionals from industry, including suppliers, manufacturers, engineers, researchers and professors, to expand the body of knowledge and to develop and enhance the Specification (AISI, 2001a). An increased interest in cold-formed steel for residential and light commercial framing began in the mid-1990's. Although the AISI Specification had gained acceptance and was in widespread use by that time, there were a number of design issues that were not adequately addressed for this emerging market. As AISI considered the needs of the light framing industry, it assessed the scope, limitations and complexity of its Specification and noted that the emphasis was on member

design, primarily for traditional C and Z shapes. However, within typical light framing applications there were many applications where the members would be used in systems not explicitly addressed by the Specification, such as built-up headers (*Figure 2*) and shear walls, and complex shapes developed for such things as truss chords (*Figure 3*). In addition, to facilitate the needs of homebuilders, an industry consensus prescriptive method was needed which would allow builders to build with standard details and simply look-up member sizes in easy to use tables.

In 1997, AISI expanded its standards development activity to support the growing needs of the cold formed steel framing industry. Rather than add to the complexity of the AISI Specification, it was decided that a new family of standards should be developed. Specifically, there was a need to supplement the AISI Specification with a general provisions standard, a family of application-oriented design standards, and a focused prescriptive method for residential construction. A new committee was formed, called the Committee on Framing Standards (COFS), to operate under the same ANSI-approved operating procedures as the existing AISI Committee on Specifications.

The COFS established as its mission: "To eliminate regulatory barriers and increase the reliability and cost competitiveness of cold-formed steel framing in residential and light commercial building construction

through improved design and installation standards." The committee also established as its primary objective: "To develop and maintain consensus standards for cold-formed steel framing, manufactured from carbon or low alloy flat rolled steel, that describe reliable and economical design and installation practices for compliance with building code requirements." The committee operates with various subcommittees and task groups; however, the main committee always maintains control of all decisions through the balloting process. By 2001, the COFS had completed four standards for cold-formed steel framing (*Figure 1*), namely the General Provisions (2001b), Header Design (2001c), Truss Design (2001d) and Prescriptive Method for One and Two Family Dwellings (2001e). These ANSI-accredited standards were subsequently adopted by the ICC (ICC, 2003a and ICC, 2003b) and NFPA (NFPA, 2002) model building codes. In 2003, a comprehensive Commentary on the Prescriptive Method, including technical substantiation and design examples, was completed (2003).

The Standards

The *General Provisions Standard* addresses all provisions that are common to prescriptive and engineered design, and provides a link between all of the industry stakeholders and code enforcement agencies, ensuring everyone is "on the same page" with the basic requirements of cold-formed steel framing. The document contents range from member identification and labeling through basic installation tolerances such as in-line framing tolerances. The scope of the General Provisions

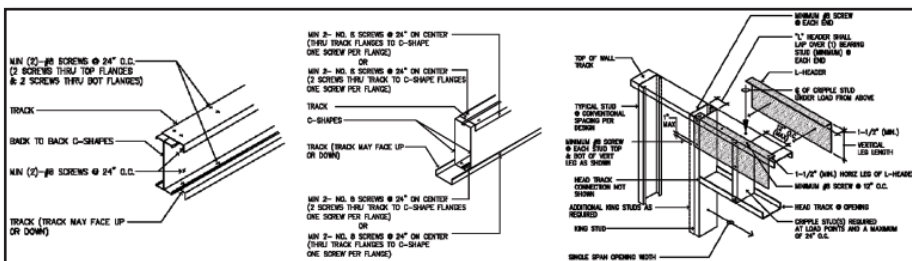

Figure 2 Back-to-Back, Box and L-Header Assemblies

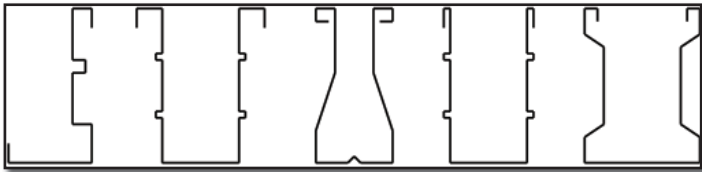

Figure 3 Proprietary Truss Chord Shapes

standard states that it applies to structural and non-structural cold-formed steel framing members where the specified minimum base metal thickness is between 0.018" to 0.118". It is important to recognize that this standard is not intended to apply to such things as metal buildings or structural steel buildings.

The *Header Design Standard* is aimed at giving design professionals the tools they need to design efficient built-up headers and L-headers. The design methodologies are based on testing by the NAHB Research Center, the University of Missouri at Rolla and industry stakeholders, and were developed under the guidance of Dr. Roger LaBoube of the University of Missouri at Rolla. The Header Design Standard serves as a supplement to the AISI Specification, and addresses back-to-back, box and L-header assemblies (Figure 2).

The *Truss Design Standard* provides technical information and specifications for cold-formed steel truss construction. This Standard applies to the design, quality assurance, installation and testing of cold-formed steel trusses used for load carrying purposes in buildings. The Truss Standard serves as a supplement to the AISI Specification. It addresses design responsibilities and provides requirements for loading, truss design, quality criteria, installation and bracing, and test methods. The requirements of this standard apply to both generic C-section trusses, as well as the various proprietary truss chord shapes (Figure 3).

The *Prescriptive Method Standard* is an updated version of previous submittals to the residential building code (ICC, 2000) that has gone through the rigorous consensus process, earning it ANSI recognition, giving it instant credibility and making it easily accepted by the various building codes. The standard incorporates all of the latest cost saving developments of the Steel Framing Alliance, such as the L-header, coupled with the latest engineering and load combination developments, such as ASCE 7-98 (ASCE, 1998) and the LRFD provisions of the AISI Specification. The provisions apply to the construction of detached one- or two-family dwellings, townhouses, and other attached single-family dwellings not more than two stories in height using repetitive in-line framing practices. This document provides span-load tables, connection requirements and details (Figure 4) for framing a typical residential building in steel.

Looking Forward

The COFS has by no means completed its mission. It is currently working on ANSI accredited standards for Wall Stud Design and Lateral Design, and is leading an effort to develop an industry Code of Standard Practice. These state-of-the-art documents should be completed in 2004. (An overview of the Wall Stud Design standard is included in this issue as a companion article. See page 14.)

Summary

The American Iron & Steel Institute has effectively leveraged its experience and expertise

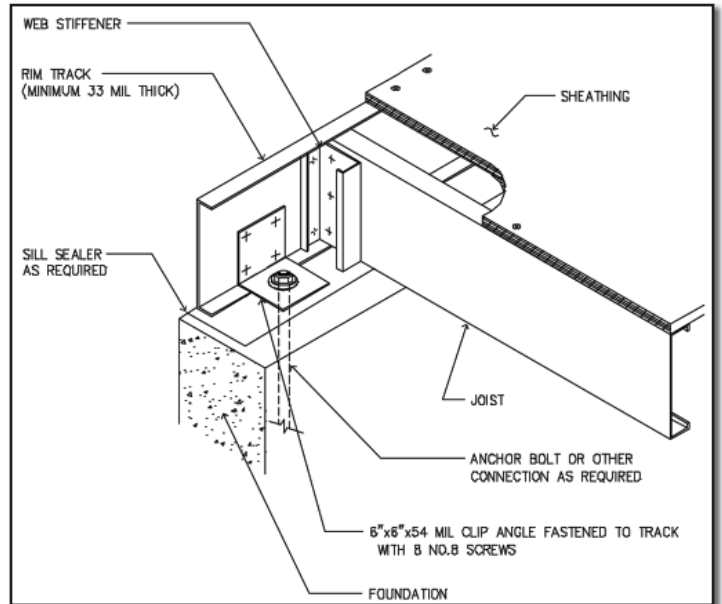

Figure 4 Typical Prescriptive Detail

in standards development to support the growing needs of the cold-formed steel framing industry. Charged with a mission, to eliminate regulatory barriers and increase the reliability and cost competitiveness of cold-formed steel framing through improved design and installation standards, the Committee on Framing Standards built on the internationally

Introducing . . .

Dr. Frame3D

Real Analysis in Real-Time!

- Manipulate all components with real-time visual and numeric feedback!
- Better designs—faster!
- Perfect for “What if . . . ?” scenarios, preliminary designs, retrofit options, etc.

Mention this ad for \$100 off pro license

Dr. Software, LLC

Seattle, Washington ■ 206-930-5828

www.drframe.com

For Advertiser Information, visit www.structuresmag.org

recognized AISI Specification, developed four ANSI-accredited consensus standards and is nearing completion on three new documents. These documents have widespread application and building code acceptance, and are readily available from the American Iron & Steel Institute (www.steel.org) and the Steel Framing Alliance (www.steel framingalliance.com).

Jay W. Larson, P.E., FASCE is the Director of Construction Standards Development for the American Iron & Steel Institute, Washington, DC. Jay has 25 years of engineering experience in the steel industry, with 13 of those years in cold-formed steel product, market and standards development efforts.

Part 2: Wall Stud Design (2004) Standard

By: Roger A. LaBoube

As described by Mr. Larson in the companion Codes & Standards article, the *North American Specification for the Design of Cold-Formed Steel Structural Members* (North, 2001) is a document that addresses the design of individual members and connections. However, cold-formed steel members are generally components of an assembly or a system, and the Specification does not reflect the potential positive attributes attributable to system synergy. Research has shown that assembly or system synergy is important in the design of cold-formed steel wall stud assemblies.

The Committee on Framing Standards (COFS) develop and maintain “consensus” standards for cold-formed steel framing, manufactured from carbon or low alloy flat rolled steel, that describe reliable and economical design and installation practices for compliance with building code requirements.

A key attribute of the design standard is the consideration for the synergistic behavior of the wall assembly components. Also, unlike the Specification (North, 2001), the Standards address proper installation of the cold-formed steel components. *Figure 1* depicts a typical wall framing assembly.

The following is a brief technical overview of key design requirements of the *Standard for Cold-Formed Steel Framing – Wall Stud Design* (2004).

Wall Stud Design Standard

The *Standard for Cold-Formed Steel Framing – Wall Stud Design* (2004) provides requirements for design of structural, curtain wall, and non-structural walls. As with the General Provisions (2001a) Standard, the Wall Stud Standard is applicable to cold-formed steel members with material thickness ranging from 18 mils to 118 mils. A structural wall supports superimposed axial loads and may transfer lateral loads. A curtain wall transfers lateral loads and is limited to superimposed vertical load of not more than

100 lb/ft, or a superimposed vertical load of not more than 200 lbs. A non-structural wall is limited to a lateral load of not more than 5 lb/ft² and a superimposed vertical load of not more than 100 lb/ft, or a superimposed vertical load of not more than 200 lbs.

The Standard provides requirements for design based on either an all-steel design or sheathing braced design. The all-steel design uses the provisions of the Specification (North, 2001) and neglects the beneficial effect of the sheathing material. The sheathing braced design utilizes the wall sheathing to brace the wall stud for both axial compression and flexure.

Sheathing Braced Design. Sheathing braced design in the Standard is based on rational analysis assuming that the sheathing braces the stud at the location of each sheathing-to-stud fastener location. Therefore, the unbraced length with respect to the major axis is taken as the distance between the member’s ends. The unbraced length with respect to the minor axis and the torsion axis is a function of the distance between the sheathing connectors. The axial load capacity of the stud is also limited by the capacity of the sheathing or sheathing-to-wall stud connection. Using the bracing principles

as defined by Winter (1960) and summarized by Yu (2000) in which the brace force is given as follows:

$$F_{br} = K (\Delta + \Delta_o) = 0.02 P$$

Where:

$$K = 4P/L$$

$$\Delta = \Delta_o = L/384$$

L = total stud height

The limit of L/384 is based on the maximum bow of 1/32 inch/foot as prescribed by Table A5.1 of the *General Provisions* (2001a).

The strength of sheathing attached with No. 8 and No. 6 screws is based on tests by Miller (1989) and Lee (1995), respectively. Based on engineering judgment, a factor of safety of 2.0 was applied to the ultimate load when determining the allowable load for the gypsum wallboard.

To prevent failure of the sheathing or sheathing-to-wall stud connection, when the

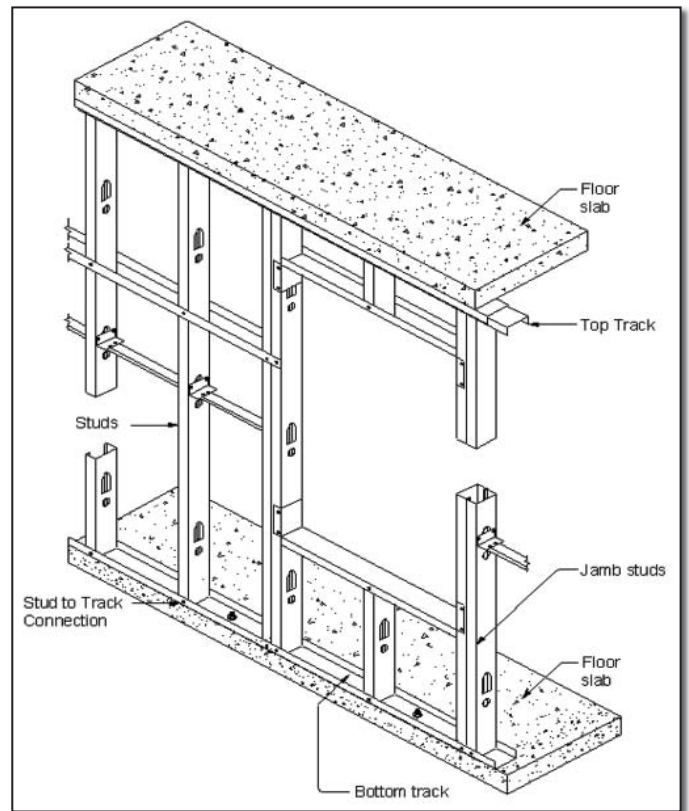

Figure 1 Typical Wall Assembly

Sheathing	Screw Size	Ultimate Load (per screw)	Allowable Load (per screw)
1/2"	#6	0.117 kips (0.516 kN)	0.058 kips (0.258 kN)
1/2"	#8	0.134 kips (0.596 kN)	0.067 kips (0.298 kN)
5/8"	#6	0.136 kips (0.605 kN)	0.068 kips (0.302 kN)
5/8"	#8	0.156 kips (0.694 kN)	0.078 kips (0.347 kN)

Table 1 Sheathing or Sheathing-to-Wall Stud Connection

identical gypsum sheathing is attached to both sides of the wall stud with screws spaced 12 inches (300 mm) on center, the maximum nominal axial load in the wall stud is limited to the values given in *Table 2*. For other sheathing materials, rational analysis may be used to determine appropriate allowable loads.

The unbraced length with respect to the minor axis and the unbraced length for torsion are taken as twice the distance between the sheathing connectors in the event that an occasional attachment is defective to a degree that it is completely inoperative.

Connection Design. The self-drilling screw

is the most common fastener used to fabricate steel-to-steel connections in cold-formed steel wall assemblies. Design strength for a screw connection is stipulated by the *North American Specification for the Design of Cold-Formed Steel Structural Members* (North, 2001), however requirements for installation of screws in cold-formed steel framing are provided by the design standards.

For curtain wall assemblies, the Wall Stud Design standard provides design provisions that result in enhanced lateral load carrying performance for the bottom stud to track connection (*Figure 1*). The enhanced performance is attributed to the synergistic relationship between the wall stud, the bottom track, and the screw attachment.

The top track's design is unique because it must accommodate for vertical deflection of the floor slab as well as transfer applied lateral wind load (*Figure 1*). Thus, there is no fastener affixing the stud to the track flange. The lateral load transfer between the wall stud and the track is achieved through bending of the track flange. The wall stud standard provides provisions for evaluating the load transfer capability of the track flange.

Installation. Proper installation of the wall stud assembly is critical to achieving the desired design structural performance. The Standard stipulates that, for a curtain wall system, the studs are to be seated squarely in the track with no more than a 1/4 inch (6.4 mm) gap between the end of the stud and the track. For a structural wall, i.e. axial load bearing, a more stringent 1/8-inch (3.2 mm) gap is prescribed.

Conclusion

To learn more about the wall stud design standard and the activities of the American Iron and Steel Institute or the Steel Framing Alliance, refer to their respective web sites www.steel.org and www.steel Framing Alliance.com.

Acknowledgement

The author acknowledges and is grateful for the contributions of the COFS committee members. Without their untiring efforts this design standard would not have been created. ■

Roger A. LaBoube is a Distinguished Teaching Professor of Civil Engineering and Director of the Wei-Wen Yu Center for Cold-Formed Steel Structures, University of Missouri-Rolla, Rolla, MO.

References for this article, and other STRUCTURE articles, are included in the on-line version. Please visit www.structuremag.org



Sheathing	Screw Size	Maximum Nominal Axial Load
1/2"	#6	5.8 kips (25.8 kN)
1/2"	#8	6.7 kips (29.8 kN)
5/8"	#6	6.8 kips (30.2 kN)
5/8"	#8	7.8 kips (34.7 kN)

Table 2 Sheathing or Sheathing-to-Wall Stud Connection Capacity