

codes & standards

High-Wind and Seismic Issues for Wood-Frame Construction

An Overview of the 2001 ANSI/AF&PA Wood Frame Construction Manual for One- and Two-Family Dwellings

By Scott Lockyear, P.E.

Over the last 20 years, building construction regulators and insurance underwriters have increasingly questioned whether existing prescriptive code provisions for conventional wood-frame construction are technically justified. Such concerns with conventional construction are largely the result of damage to wood-frame structures by hurricanes and earthquakes in the 1980s and 1990s.

While most structural damage from high-wind and seismic events has been attributed to lack of code compliance, the wood industry nonetheless has sought to develop prescriptive design provisions based on engineering principles for high-wind and seismic regions. The culmination of this effort to date is the 2001 Wood Frame Construction Manual for One- and Two-Family Dwellings (WFCM), published by the American Forest & Paper Association (AF & PA).

Wood Frame Construction Manual

The WFCM was initially published in 1996, after almost ten years of development by AF&PA. Shortly after publication, the *Wood Frame Construction Manual for One- and Two-Family Dwellings, 1995 High Wind Edition* was approved as a reference standard in the 1997 *Standard Building Code* (SBC) as an acceptable method for design and construction of one- and two-family residences. In recognition of its beneficial provisions, the 1995 WFCM was subsequently approved for use in the 1999 *National Building Code*, 2000 *International Building Code*® (IBC®) and 2000 *International Residential Code*® (IRC®).

Building on widespread acceptance of the 1995 WFCM, AF&PA developed the 2001 edition to cover design of wood-frame buildings for the entire U.S. The 2001 WFCM has since been adopted into the 2003 IBC and 2003 IRC.

The 2001 WFCM addresses wood-frame design in all regions of the country, including areas subject to extreme wind, snow and seismic events. The wind, snow and seismic loads are based on the 2000 IBC, while design resistances for members and connections are based on the 1997 *ANSI/AF & PA National Design Specification for Wood Construction*.

The 2001 WFCM consists of a set of two books: the WFCM itself and a commentary (*Figure 1*). The WFCM has three chapters and a supplement. Chapter 1 presents general information that applies to the entire document, including scoping limitations, definitions and

referenced standards. Chapter 2 provides engineered load and capacity tables and construction details for I-joists and trusses. Chapter 3 presents prescriptive methods of design and construction derived from the load tables in Chapter 2, thereby enabling the user to mix the prescriptive methods with the engineered solutions. The supplement section provides design resistances for structural members, nail connection capacities, allowable spans for floor and roof sheathing, and shear capacities for horizontal diaphragms and shear walls, which

are used to generate Chapter 3's prescriptive solutions.

The WFCM *Commentary* provides background information and example calculations for various sections and tables of the manual. Background information is intended to give the reader an in-depth understanding of the engineering principles under which the manual's provisions were developed. Examples of calculation procedures used to produce tables in the WFCM are provided to illustrate the scope of conditions covered by each table.



Figure 1: Wood Frame Construction Manual and Commentary

WFCM Prescriptive Construction Provisions

Chapter 3 of the 2001 WFCM provides prescriptive solutions for dwellings up to three stories, 33-feet high, with roof slopes from 0 to 45 degrees. For roof slopes 6 in 12 or greater, the attic space is considered to be an additional story (Figure 2).

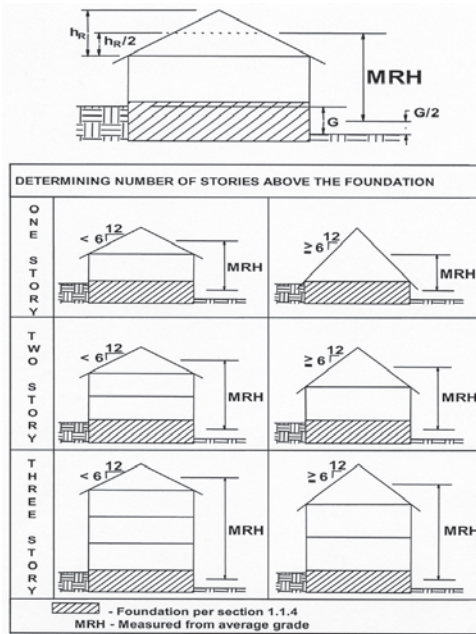

Figure 2: Determining the number of stories above the foundation

Prescriptive solutions are provided for resistance of gravity loads from occupancy, construction and snow, in addition to uplift, lateral and shear forces from wind and seismic loads (Figure 3). Design loads for snow are based on ground snow loads ranging from 0–70 pounds per square feet. Loads due to wind are based on 3-second-gust wind speeds of 85–150 miles per hour, Exposures B and C. Seismic design uses the IBC simplified design procedure and may be used for Seismic Design Categories A–D.

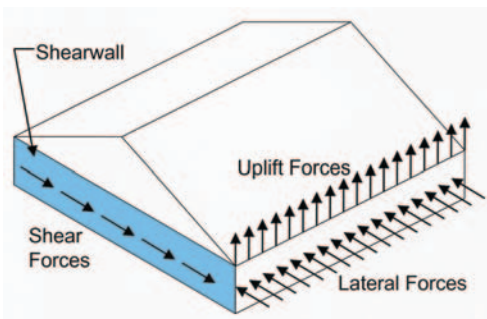

Figure 3: Uplift, lateral and shear loads

Attention to forces created by these loads allows the building designer to adequately size framing members and fasteners. Attention to fastening is especially critical if a continuous load path is to be maintained to transfer all forces from the roof, wall and floor to the foundation system.

Tabulated design resistances for structural members are given for the major species of Douglas Fir-Larch, Hem-Fir, Southern Pine and Spruce Pine-Fir. Connection capacities are given for common and box nails. In addition, connection load tables from the engineered design provisions of Chapter 2 are reproduced in the prescriptive provisions to facilitate use of proprietary connectors.

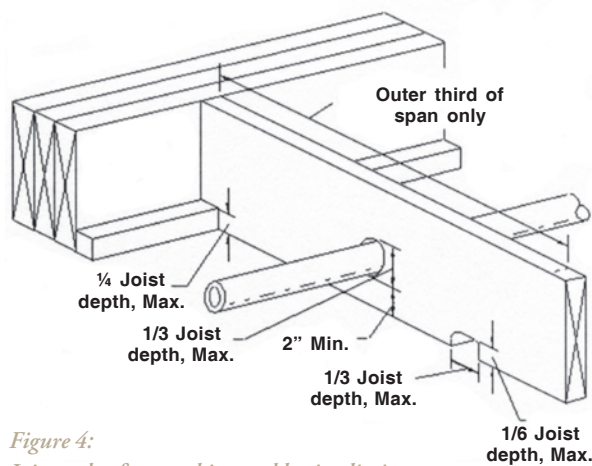

Figure 4: Joist and rafter notching and boring limits

Many of the tables in Chapter 3 include condensed information covering more than one design condition. In order to make the tables and other provisions of the standard readily understandable, typical construction details are presented throughout the WFCM to clarify

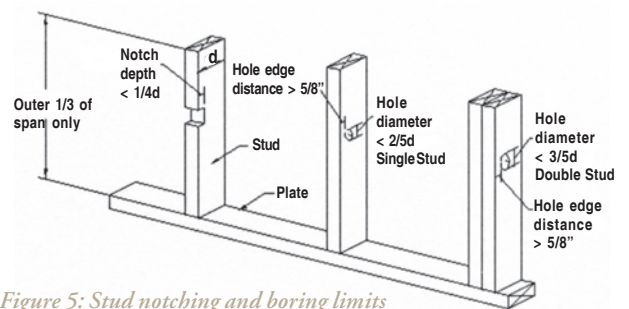

Figure 5: Stud notching and boring limits

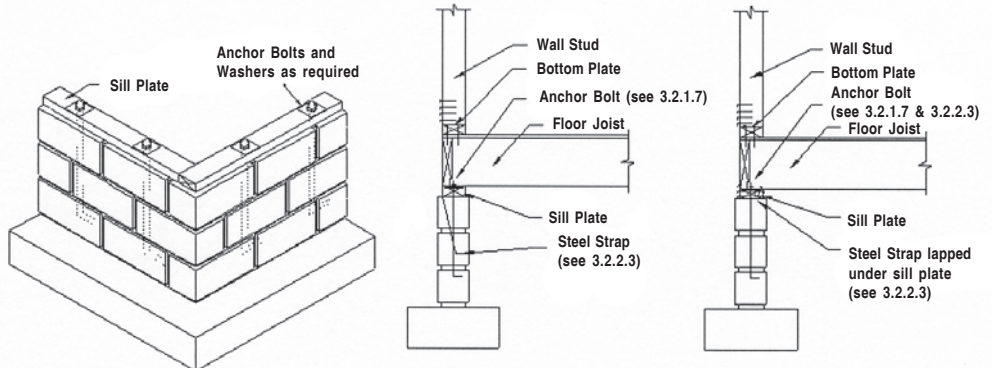

Figure 6: Sill plate anchorage to masonry or foundation

issues and illustrate acceptable methods of construction. These details were derived from building code provisions and industry standards of good practice. For example, Figures 4 and 5 (taken from the WFCM) illustrate notching and boring limitations for joists, rafters and studs. These limitations are the same as those in the model building codes.

The WFCM does not include design guidelines for foundations. Instead, the manual relies on design of the foundation system by a competent individual in accordance with building code requirements. However, the WFCM does provide specifications for fastening wood-frame structures to foundations addressing the prescriptive use of 1/2-inch and 5/8-inch anchor bolts (Figure 6).

The provisions of the WFCM are not intended to prevent the use of other materials or methods of construction. When a product or procedure can be shown to provide equivalent or greater resistance, the product or procedure can be accepted by the authorized jurisdiction as conforming to the document.

State-of-the-Art Design Procedures

In developing the WFCM, an effort has been made to incorporate state-of-the-art design procedures as they become available in order to more accurately account for the actual performance of a wood-frame structure. Some of the design procedures of particular significance include the repetitive member factor for wall studs based on partial composite action and load sharing, perforated shear-wall design method, 1.4 increase for shear-wall and diaphragm capacities, and summing shear capacities of dissimilar materials.

Repetitive Member Factors for Wall Studs

Wall studs in an assembly sheathed on both sides are generally stronger and stiffer than those in similar, unsheathed wall assemblies.

The enhanced performance, or “system effect,” is commonly quantified by considering the effects of partial composite action and load sharing.

New repetitive-member factors for wood stud wall assemblies were added to the 1997 SBC. These factors were based on a study of wood stud walls that found that partial composite action and load sharing, which occur in a common 2x4 wall assembly with wood structural panel and gypsum wallboard sheathing, produce wall strengths 1.56 times greater than would be predicted by traditional single-member design (Polensek 1976). Based on subsequent modeling, repetitive-member factors were developed for use in the design of wall studs sheathed with a wood structural panel exterior sheathing and interior gypsum wallboard. These values are provided in Table 1.

Stud Size	Repetitive Member Factor
2x4	1.50
2x6	1.35
2x8	1.25
2x10	1.20
2x12	1.15

Table 1: Repetitive member factor for wall studs resisting wind

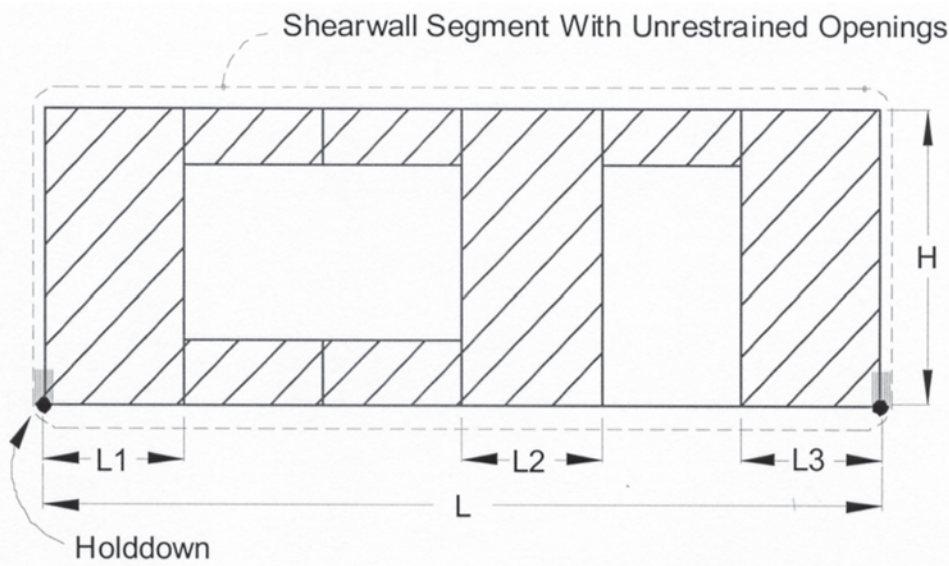

Figure 7: Typical perforated shearwall with unrestrained openings



WFCM Workbook Design House

Wood Building Design Workshop

As a way of encouraging proper design and construction of wood-frame buildings, the AF&PA American Wood Council (AWC) has developed an in-depth workshop on using the WFCM. The workshop includes classroom instruction and awards continuing education units. Participants are provided with a copy of the WFCM and a design workbook which includes a comprehensive design example. The workbook also includes a design template for use after the workshop when designing other buildings using the WFCM.

Workshop participants are familiarized with the WFCM through analysis of a typical two-story house designed from roof to foundation for Seismic Design Category D1; a ground snow load of 30 pounds per square foot; and an Exposure B, 3-second-gust 120 mph wind speed. The focus of the course is practical design using permitted tables from the WFCM. Learning how to efficiently use the WFCM is valuable as it offers a method of design that requires a minimum amount of time commitment by the designer.

Although designers of wood-frame dwellings are the primary audience for the course, building contractors and code officials will also benefit from familiarizing themselves with the tables, specifications, illustrations and general design concepts.

For those who cannot attend the WFCM workshop, AF&PA offers a web-based course and electronic workbook through its website.

For more information on the WFCM, AWC's wood building design course or other educational materials, visit AWC's website at www.awc.org.

Perforated Shear Wall Design Method

The perforated shear wall method was developed to account for the reduced shear capacity of a shear wall when full overturning restraint is not provided at each full-height segment. Based on research performed in Japan (Sugiyama 1981) and other summarized research (Douglas et. al. 1994), the method allows for design of shear wall segments without intermediate overturning restraint next to openings (*Figure 7*). Both the segmented method, which assumes hold-downs for each full height segment, and the perforated shear-wall method have been incorporated in the WFCM.

Increased Shear Wall and Diaphragm Capacities for Wind Loads

Historically, the minimum safety factor on wood structural panel shear walls and diaphragms resisting wind loads has been 2.8. This safety factor is often in excess of what is typically required for other components in wood-frame construction. A 40-percent increase is now allowed for shear wall and diaphragm capacity when resisting wind loads. This change was incorporated into the 1997 SBC, 2000 IBC, and wood industry standards and literature.

In addition to increasing wood structural panel resistance to wind, the contribution of interior sheathing was taken into account in the design. Historically, the contribution of interior gypsum wallboard has been ignored. Provisions in the SBC, 2000 IBC, and industry standards and literature now recognize that summing of materials is allowed for wind loads. Both the increase in shear-wall and diaphragm capacity and the summing of dissimilar materials are included in the 2001 WFCM.

Conclusion

Over the past two decades, new prescriptive design methods for wood-frame construction have been developed based on engineering mechanics and adopted by the model codes. Engineered prescriptive solutions are often used in high natural-hazard regions where the limits

of conventional construction in the building codes may be exceeded. AF&PA's WFCM provides both engineered and prescriptive solutions for wood-frame structures subject to high wind, seismic and snow loads.

Scott Lockyear, P.E., is a Structural Engineer with the American Wood Council and the American Forest & Paper Association, in Washington, D.C.

References

- Douglas, B. K., H. Sugiyama. "Perforated Shear Wall Design Approach." Presented at the 1994 American Society of Agricultural Engineers International Winter Meeting. Paper No. 944548. American Society of Agricultural Engineers, St. Joseph, MI.
- Polensek, Anton. "Rational Design Procedure for Wood-Stud Walls Under Bending and Compression Loads." *Wood Science*. Vol. 9, No.1. 1976.
- Sugiyama, Hideo, "The Evaluation of Shear Strength of Plywood-Sheathed Walls with Openings." *Mokuzai Kogyu (Wood Industry)*. Vol. 36, No. 7. 1981.

**USP
Lumber Connectors
1/2, IS, 4C
Royle to place from zip dics
also need Royle to make use a PDF**

For Advertiser Information, visit www.STRUCTUREMAG.org