

Continuous Tie-Down Systems for Wood Panel Shear Walls in Multi Story Structures

February 21, 2003 update of a paper presented at the Structural Engineers Association of California Convention October 28, 2002

Ronald F. "Rawn" Nelson, S.E., R. F. Nelson & Assoc., Hermosa Beach, CA

Sharad T. Patel, S.E., VCA Engineers, Orange, CA

Ricardo Arevalo, S.E., Simpson Strong-Tie Co., Brea, CA

ABSTRACT

With the recent increase in construction of three and four story wood framed structures (examples shown in Pictures 1 & 2) has come a demand from builders and engineers for an alternative from the "traditional" shear wall hold-down systems. The loads generated in such structures is commonly in the range of 30 to 40 kips on the ground floor. To accommodate such loads using "traditional" systems has at times proven to be time consuming and expensive to install. Continuous tie-down systems are a relatively new, simple, and economical solutions

The design and detailing procedures for these types of hold-down systems are not the same as the "traditional" hold-down systems. This paper presents a generic review of design issues (uplift load accumulation and transfer principles, shear wall drift, compression of wood end-posts (perpendicular and parallel to grain), shrinkage of wood framing members, elongation of rod or cable, etc.) and a brief review of the detailing and specifying of these systems.

INTRODUCTION

Structural tie-downs are required to resist the uplift, on wood panel shear walls, caused by overturning moments induced by lateral loads. These tie-downs are part of a load path that transfers uplift forces to the foundation or base concrete slab. Examples of

existing "traditional" tie-downs (hold-downs) on the market today are metal straps, bent/folded steel devices or structural steel sections in combination with steel anchor rods. Most of these hold-down systems are proprietary and have ICBO ES approvals. Additional advantages in most of these systems:

- Shrinkage compensation is possible
- Economic
- Concentric/High capacity
- Simple installation and inspection

The continuous tie-down systems use a continuous series of connected rods or cable that collect and transfer shear wall uplift forces, from multiple levels, to the foundation or base. Uplift forces are transferred to the rod or cable via concentric steel plates bearing above the shear wall (in some cases the upper bearing plate is within the height of the shear wall) or via bolted concentric hold-down devices located within the height of the shear wall.

This paper presents a generic review of design issues [uplift load accumulation and transfer principles, shear wall drift, compression of wood end-posts (perpendicular and parallel to grain), shrinkage of wood framing members, elongation of rod or cable, etc.] and a brief review of the issues revolving around detailing and specifying these systems. Generic representations of continuous tie-down systems are shown in Figures 1A & 1B.

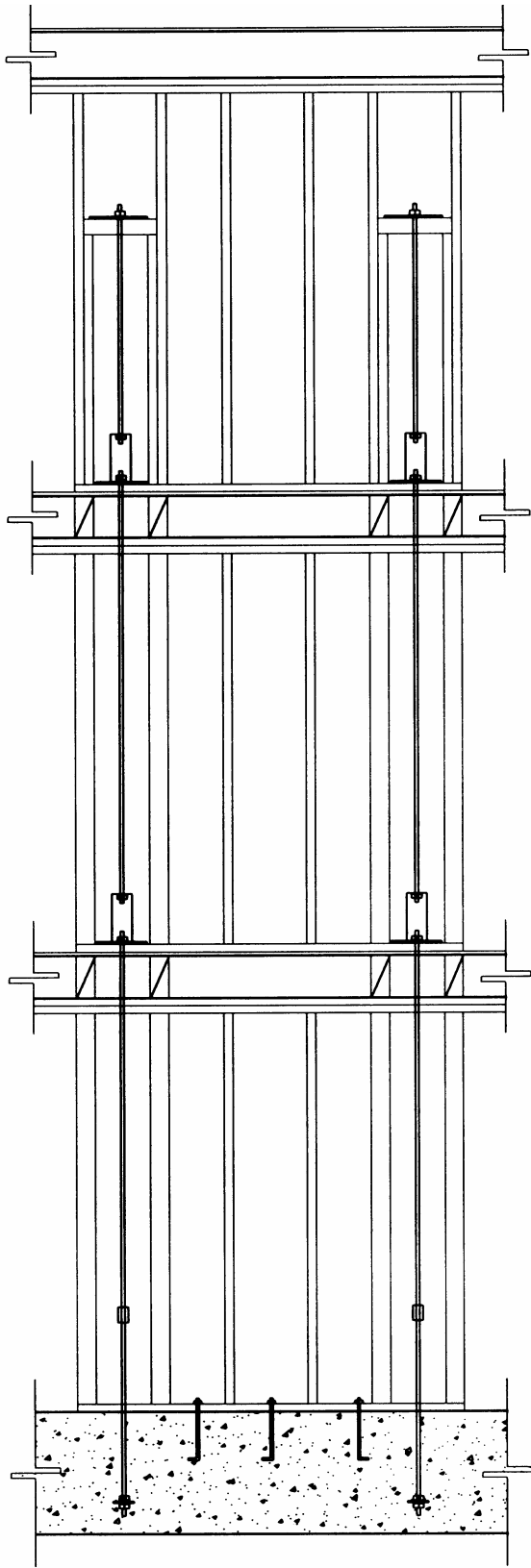

Figure 1A. Illustration of a continuous concentric tie-down system using bearing plates.

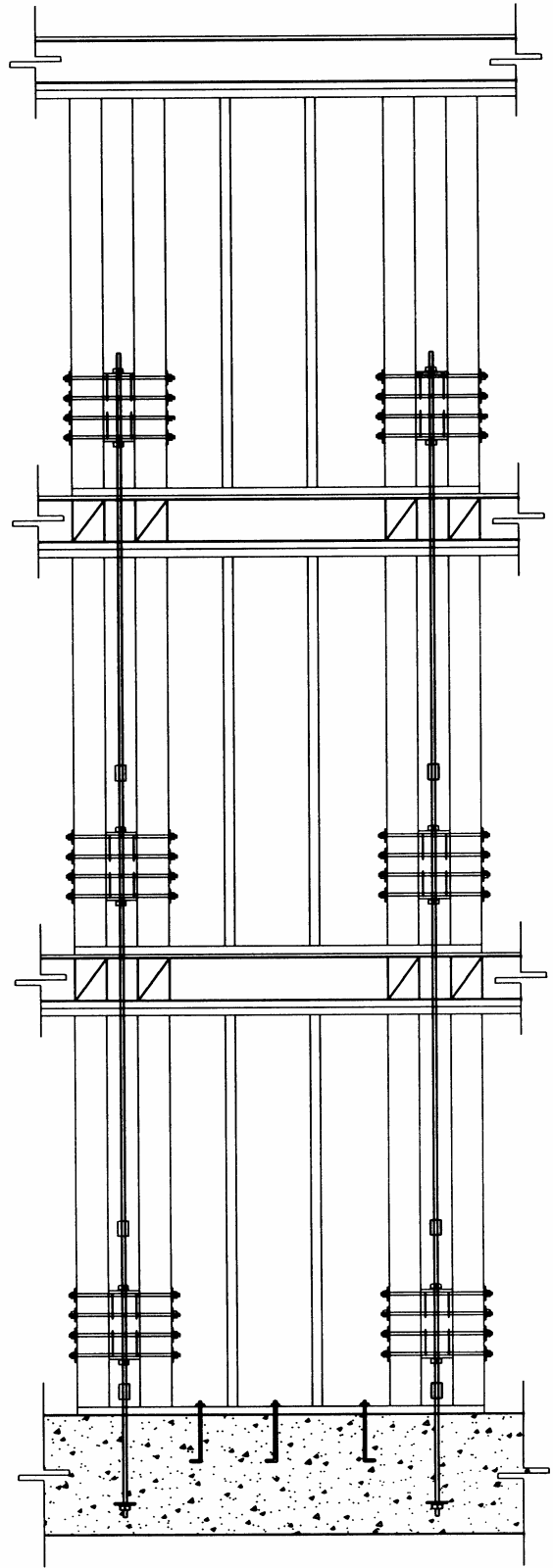

Figure 1B. Illustration of a continuous concentric tie-down system using bolted hold-down devices.



Picture 1. Example of multi story narrow shear wall



Picture 2. Example of multi story narrow shear wall

DESIGN ISSUES

Design of wood shear walls has traditionally been limited to utilizing code approved allowable stresses (in plf) coupled with limits on the aspect ratio of the shear walls. The tension and compression capacity of the end-posts, shear wall deflection, shrinkage, and eccentric loading have sometimes been ignored. However, code compliant structural calculations should be used to check all of the components of the shear wall. The basic steps are reviewed below.

The determination of rigid or flexible diaphragm is important for how diaphragm loads are distributed to supporting members. Shear walls in wood framed residential structures are often closely spaced (usually 15'-20' apart). Diaphragm deflection is relatively small compared to shear wall deflection. Concrete topping and glued floor sheathing contribute to diaphragm rigidity. Figure 2 shows the definition of a flexible diaphragm.

Determination of the rigidities of wood shear walls is often difficult and inexact. The current code deflection equations were developed more than three decades ago and have changed very little. An example of ignoring shear wall rigidities is shown in Figure 3.

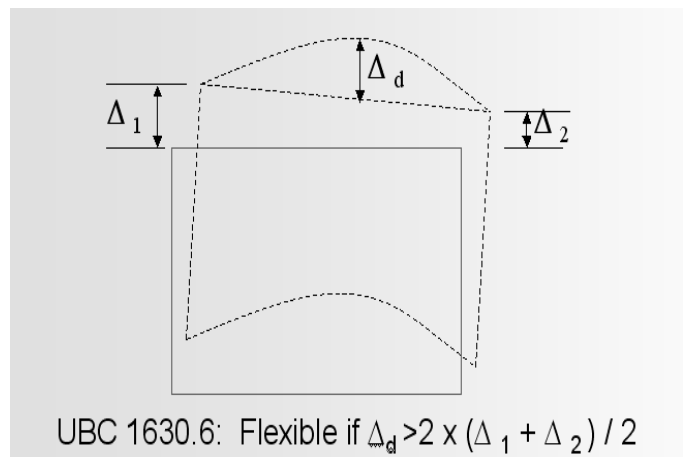

Figure 2. Flexible diaphragm definition.

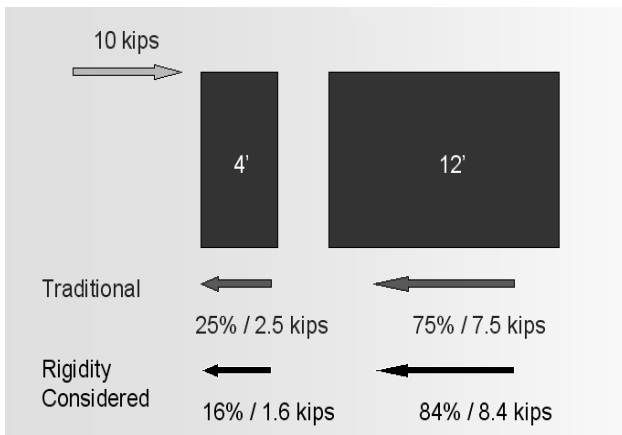

Figure 3. Example of ignoring rigidity of walls along a line.

Recommended Shear Wall Design Steps

1. Determine lateral load using code approved base shear formulas coupled with site specific (when available) seismic criteria.
2. Distribute load vertically to stories in the structure.
3. and resisting elements (flexible diaphragm assumption should not be made without verification of diaphragm deflection relative to shear wall deflection).
4. Design/select wood sheathing and fasteners.
5. Design/select base horizontal anchorage.
6. Design/select **overturning anchorage**.
7. Check wood framing members for moisture content. Include shrinkage in shear wall displacement calculations.
8. Check shear wall displacement against code allowable.

Overturning Anchorage

Code References:

Design:

UBC§1605.2 and IBC§1604.4 ...analysis shall result in a system that provides a complete load path capable of transferring all loads and forces from their point of origin to the load-resisting elements

Wind Overturning Resistance:

UBC§1621.1 The base overturning moment for the entire structure, or for any one of its individual primary lateral-resisting elements, shall not exceed two thirds of the dead-load-resisting moment.

IBC§1609.1.3 Where the alternate basic load combinations of Section 1605.3.2 are used, only two thirds of the minimum dead load likely to be in place during a design wind event may be used.

Seismic Overturning Resistance:

UBC§1630.8 Every structure shall be designed to resist the overturning effects caused by earthquake forces specified in Section 1630.5 ... (ASD: $0.9 D \pm E/1.4$).

IBC§1617.4.5 The building shall be designed to resist overturning effects caused by seismic forces determined in Section 1617.4.3 ... (ASD: $0.9 D \pm E/1.4$).

Uplift Accumulation and Transfer. Uplift forces are calculated as the overturning moment at a level divided by the distance between the centerlines of tension resistance (tie-down) and the compression resistance (end-posts). The overturning moment at a particular level is the summation of all lateral forces from above times the height from the level under consideration to the applied force.

$$\text{Gross Uplift Force: } (UF) = \sum_x^n \frac{f_x * h_x}{l'_x}$$

Resisting Force (RF) =

Accumulation of allowed vertical dead loads times the dimension from the center of the compression member divided by l'_x

Net Uplift = (UF) – (RF)

Where:

f_x = Design force at level x

h = Shear wall height

h_x = Height from base ($x=0$) to level x

l = Shear wall length

l' = Lever arm for overturning

n = Uppermost level

x = Level that is under consideration

The designer should specify the **accumulated** uplift force at each level on the design documents. Uplift forces must be calculated for each level. Examples are shown in Table 1 and Figure 4. Note that the last column in Table 1 is the statically correct calculation and will always yield a higher uplift load at lower levels of the structure. However, some engineers use the second column when the building floor system is relatively shallow.

The bearing plate or bolted hold-down device element, of the continuous tie-down system, must be capable of transferring to the rod/cable all of the accumulated uplift forces from shear walls at levels below the level where the device is installed if those

Level x	Gross UF_x at a Given Level (without floor depth)			UF_x at a Given Level Accumulated About Given Level
	Individual UF_x at a Given Level	Accumulated		
3	$\frac{h_{3-4} * f_4}{l'}$	UF_{31}	=	$\frac{h_{3-4} * f_4}{l'}$
2	$\frac{h_{2-3} * (f_3 + f_4)}{l'}$	$\sum_2^3 UF_{xl}$	\leq	$\frac{(h_{2-3} * f_3) + (h_{2-4} * f_4)}{l'}$
1	$\frac{h_{1-2} * (f_2 + f_3 + f_4)}{l'}$	$\sum_1^3 UF_{xl}$	\leq	$\frac{(h_{1-2} * f_2) + (h_{1-3} * f_3) + (h_{1-4} * f_4)}{l'}$
0	$\frac{h_{0-1} * (f_1 + f_2 + f_3 + f_4)}{l'}$	$\sum_0^3 UF_{xl}$	\leq	$\frac{(h_{0-1} * f_1) + (h_{0-2} * f_2) + (h_{0-3} * f_3) + (h_{0-4} * f_4)}{l'}$

Table 1. Example of uplift force calculations

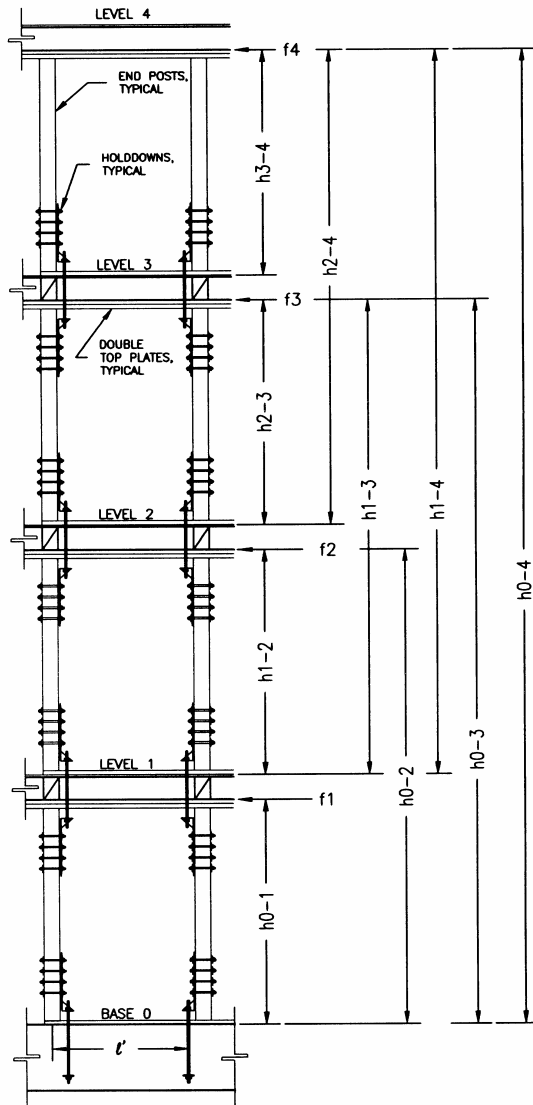

Figure 4. Illustration of shear wall design force for uplift

levels are not attached to the rod/cable (if floors are skipped).

The rod/cable, and couplers, must have the capacity to resist the accumulated loads from all transferring devices above the rod/cable location.

Anchorage at the Base or Foundation. The continuous tie-down system rod/cable must be adequately anchored to the foundation. The concrete base/foundation must also have adequate mass/strength to resist the overturning loads. The anchorage rod must be adequately designed to resist punching shear failure of the concrete, side face blowout, and all other modes of concrete failure. Consideration must be given to required edge distances, distances between anchors, etc.

Bolts and headed stud anchors or equivalent means shall be solidly cast in concrete and the services loads (nominal strength) shall not exceed the values set forth in *UBC§1923* or *IBC§1913.5*

Deflection of a Wood Shear Wall

Code References:

Wood Shear Walls and Diaphragms:

UBC§2315.1 Particleboard vertical diaphragms and lumber and wood structural panel horizontal and vertical diaphragms may be used to resist horizontal forces in vertical distributing or resisting elements, provided the deflection in the plane of the shear wall, as determined by calculations, tests or analogies drawn therefrom, does not exceed the permissible deflection of attached distributing or resisting elements

IBC§2305.2 Wood diaphragms are permitted to be used to resist horizontal forces in vertical distributing or resisting elements, provided the deflection in the plane of the shear wall, as determined by calculations, tests, or analogies drawn therefrom, does not exceed the more restrictive of the permissible deflection of attached distributing or resisting elements or the drift limits of Section 1617.3.

Drift Limitations:

UBC§1630.9.2 The Maximum Inelastic Response Displacement, Δ_M , shall be computed as follows:

$$\Delta_M = 0.7 * R * \Delta_S$$

UBC§1630.10.2 Calculated story drift using ΔM shall not exceed 0.025 times the story height for structures having a fundamental period of less than 0.7 second.

Where:

Δ_S = Design Level Response Displacement.

R = Numerical coefficient representative of the inherent over-strength and global ductility capacity of lateral force resisting systems, as set forth in UBC Table 16-N or 16-P

IBC§1617.3 The design story drift, Δ , as determined in Section 1617.4.6 or 1617.5.3, shall not exceed the allowable story drift, Δ_a , as obtained from Table 1617.3.

Deflection:

UBC§23.223, Vol. 3 and IBC §2305.3.2 The permissible deflection of a wood shear wall is shown below:

$$\Delta = \frac{8vh^3}{EAb} + \frac{vh}{Gt} + 0.75he_n + \frac{h}{b}d_a$$

Where:

A is the area of the boundary element cross section, in square inches (mm^2)

b is the shear wall length, in feet (mm)

d_a is the deflection due to anchorage details, in inches (mm), Figure 5

E is the elastic modulus of the boundary element (vertical member at shear wall boundary), in pounds per square inch (N/mm^2)

e_n is the nail deformation, in inches (mm), Table 2

G is the modulus of rigidity of the wood structural panel, in pounds per square inch (N/mm^2) Table 3

h is the shear wall height, in feet (mm)

h_{sx} is the story height below level x

t is the effective thickness of the wood structural panel for shear, in inches (mm), Table 4

v is the maximum shear at the top of the shear wall, in pounds per lineal foot (N/mm)

Δ is the calculated deflection at the top of the wall, in inches (mm)

Wood Panel Grade	G Psi
Structural I	90,000
Exterior C-C and C-D with Exterior glue with span rating: 3/8" – 24/0; 15/32", 1/2" – 32/16; 19/32", 5/8" – 42/30; 23/32", 3/4" – 48/24	90,000
All other combinations of C-C and C-D with Exterior Glue (APA Rated Sheathing)	50,000

Table 2. Modulus of rigidity values

Nominal Thickness (in.)	Effective Thickness for Shear (in)	
	APA Rated	Structural I Rated
3/8	0.278	0.371
15/32 and 1/2	0.298	0.535
19/32 and 5/8	0.319	0.707
23/32 and 3/4	0.445	0.739
7/8	0.607	0.776
1	0.842	1.088
1 1/8	0.859	1.118

Table 3. Effective thickness for shear, t .

The first term in the shear wall deflection equation represents the flexural contribution to the overall deflection. The second term represents the shear deflection and the third term represents nail deformation between the sheathing and framing. Finally, the fourth term represents the contribution of the tie-down assembly displacement.

	Min. Penetration (in)	For Max. Loads up to (lb)	Approximate Slip, e_n (in)	
			Green/Dry	Dry/Dry
8d common nail	1-7/16	220	$(V_n/857)_9^{1.86}$	$(V_n/616)^{3.018}$
10d common nail	1-5/8	260	$(V_n/977)_4^{1.89}$	$(V_n/769)^{3.276}$
14-ga staple	1 to 2	140	$(V_n/902)_4^{1.46}$	$(V_n/596)^{1.999}$
14-ga staple	2	170	$(V_n/674)_3^{1.87}$	$(V_n/461)^{2.776}$

Continuous Tie-down Assembly Displacement

Tie-down assembly displacement (d_a) is a combination of deflections contributing to the overall deflection of the shear wall:

1. Tie-down rod/cable elongation
2. Tie-down transfer device deflection
3. Oversized bolt holes for bolted hold-down devices
4. Sill/top plate crushing
5. Wood member shrinkage
6. Short posts and lack of square ends.

The total horizontal deflection at the top of a wall due to vertical displacement at the shear wall boundary is the sum of all appropriate displacements (d_a), listed above, times the aspect ratio (h/b , height/width) of the wall.

Rod/Cable Elongation. The basic equation to determine the threaded fastener (rod/cable) elongation is shown below:

$$\Delta_l = \frac{Pl_R}{AE}$$

Where:

- Δ_l is the threaded fastener elongation, on inches
- P is the accumulated uplift tension force on the threaded fastener, in kips
- A_n is the gross (nominal) area of the threaded rod, in²
- E is the modulus of elasticity of the threaded fastener, kips per square inch
- l_R is the length of the threaded fastener between load transfer devices at the level(s) being considered, in inches

It is essential to check deformation/displacements when skipping floors. Some jurisdictions have placed 1/8 inch elongation limits between load transfer components of the tie-down system.

The use of high strength rod/cable does not reduce the potential elongation. A higher load (i.e. greater capacity of A449 versus A36) over a given length and area of rod/cable will produce greater elongation. For example, elongations for 9' long A36 threaded rods stressed to their limit are in the range of 0.1". Elongations for 9' long A449 threaded rods stressed to their limit are in the range of 0.2". The result is that in most cases, high strength rods cannot be designed to their limit in some jurisdictions.

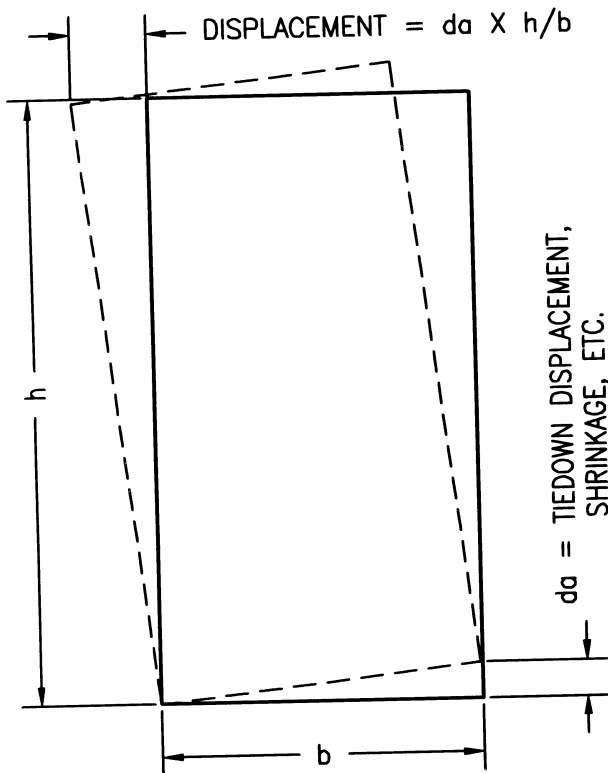

Figure 5. Shear wall deflection from tie-down displacement

Tie-down Transfer Device Deflection. The tie-down transfer device deflection varies depending on the type of device and magnitude of the load. Some of the tie-down manufacturers supply this information in their catalogs.

Typical deflections for concentric steel connectors used in bolted connections, at ASD design capacity, range from 0.013 inch to 0.037 inch.

Deflections for bearing plate component of bearing plate devices are as discussed under sill/top plate compression. Additional components may contribute to the overall deflection (elongation).

Oversized Bolt Holes. Oversized bolt holes are primarily due to the quality of construction. The contribution to anchorage device displacement from oversized bolt holes, as required by Code, ranges from 1/32 (0.0313) inch to 1/16 inch, yet can be as much as 1/8 (0.125) inch when the bolt holes are poorly installed.

Sill/Top Plate Crushing. The allowable compression stress design values ($F_{c\perp}$) perpendicular to grain are based on a deformation limit associated with a deformation level of 0.04 inches. The test-loading scheme used for determining these values is a uniform load. One method for limiting deformation, where it is critical, is the use of a reduced compression design value perpendicular to grain. For a reduced deformation limit of 0.02 inches use of $F_{c\perp 0.02} = 0.73 F_{c\perp}$. The relationship between deformations at $F_{c\perp}$ and $F_{c\perp 0.02}$ is non-linear. This corresponding deformation must be added to the vertical deflection of the anchorage system.

Shrinkage.

Code references:

UBC§2304.7 and IBC§2303.7 *Consideration shall be given in design to the possible effect of cross-grain dimensional changes considered vertically which may occur in lumber fabricated in a green condition.*

NDS Appendix A§A.3 Structural Design: *Consideration shall be given in the design to the possible effect of cross-grain dimensional changes which may occur in lumber fabricated or erected in a green condition (i.e.-provisions shall be made in the design so that if dimensional changes caused by seasoning to moisture equilibrium occur, ... the differential movement*

of similar parts meeting at connections will be minimum).

UBC§2308 and IBC§2304.3.3 *Wood stud walls and bearing partitions shall not support more than two floors and a roof unless an analysis satisfactory to the building official shows that shrinkage of the wood framing will not have adverse effects on the structure...*

Project specifications typically call for lumber to be grade stamped S-Dry (Surfaced Dry). S-Dry lumber typically has moisture content (MC) less than or equal to 19 percent at time of manufacture and the initial moisture content in service can be assumed to be 15 percent. Partially Seasoned or Green lumber grade stamped S-GRN (Surfaced Green) has a MC greater than 19 percent at time of manufacture and the initial content in service can be assumed to be 19 percent. Wet lumber has a MC greater than 30 percent.

Numerous resources for wood shrinkage information exist for different species of wood. One simplified approach uses an average shrinkage constant of 0.002 per one percent change in moisture content.

The shrinkage (S) that occurs in a dimension d of a piece of lumber is calculated as the shrinkage constant times the dimension times the change in the moisture content in the lumber (Δ_{MC}).

$$S = SV * d * \Delta_{MC}$$

Δ_{MC} will occur until the lumber MC reaches equilibrium with the ambient humidity for the project location. The final equilibrium can be higher in coastal areas and lower in inland or desert areas. These ranges are normally 15 percent (on the high end) coastal and 6 percent (on the low end) inland or desert).

Example wood shrinkage calculation:

If partially seasoned or green lumber were used during construction (MC = 19%) and assumed to reach it's equilibrium at MC = 12%,

$$\Delta_{MC} = 19\% - 12\% = 7\%.$$

2 x double top plate + 2 x sill plate ($d = 3 * 1.5$)

$$S = (0.002) (3 * 1.5) (19 - 12) = 0.063 \text{ inches}$$

2 x 12 floor joist ($d = 11.25$)

$$S = (0.002) (11.25) (19 - 12) = 0.158 \text{ inches}$$

$$S \text{ total} = 0.221 \text{ inches}$$

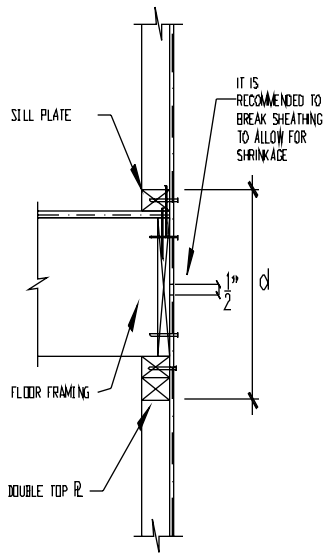

Figure 6. Wood shrinkage at framed floor

Some designers specify quality control measures that require the contractor to verify that the moisture content of lumber actually delivered to the job site is in conformance with project specifications. Higher moisture content at time of installation will increase shrinkage. Instances have been recorded where shrinkage, for the same framing system used in the example, has exceeded 0.50 inches.

The majority of the proprietary tie-down systems compensate for shrinkage by pre-tensioning of the rod or cable, or by self-ratcheting devices, or by expandable elements within the system. These shrinkage-compensating devices are highly recommended in tie-down systems for multi-level wood frame construction. Shrinkage, if not compensated for in the tie-down system, will add to the d_a term of shear wall deflection equation and allow the shear wall system to go through considerable deflections before tie-downs are even activated.

Since continuous tie-down systems are continuous, shrinkage will be accumulated, from the bottom to the top, on the rod or cable at each point of resistance. This accumulated shrinkage needs to be accounted for in the design of continuous systems.

In addition, shrinkage compensating devices will normally compensate for other slack in the tie-down system caused by crushing of plates and joists, seating of end-posts, studs, etc. Shrinkage compensating devices, when properly designed,

should eliminate loose anchorage or gaps in framing at the tops and bottoms of boundary elements.

End Posts-Compression Parallel to Grain. In multi story stacking systems compression parallel to grain on the end-posts can often be the controlling design capacity. A comparison between compression perpendicular to grain and compression parallel to grain for Douglas Fir-Larch, No. 2 wood members follows in Table 5:

b (in)	l_e (in)	C_D	P_{max} (kips)	t (in)					
				1.50	2.50	3.00	3.50		
3.5	Any	1.00	$P_{c\perp}$	3.28	5.47	6.56	7.66		
		1.33		N/A					
	91.5	1.00	$P_{c\parallel}$	3.23	5.39	6.47	7.55		
		1.33		3.37	5.61	6.73	7.86		
	103.5	1.00		2.62	4.37	5.24	6.11		
		1.33		2.69	4.49	5.39	6.29		
	115.5	1.00		2.15	3.59	4.30	5.02		
		1.33		2.20	3.66	4.39	5.13		
	127.5	1.00		1.79	2.99	3.59	4.18		
		1.33		1.82	3.04	3.64	4.25		
	5.5	Any		1.00	$P_{c\perp}$	5.16	8.59	10.31	12.03
				1.33		N/A			
103.5		1.00		$P_{c\parallel}$	7.93	13.22	15.86	18.50	
		1.33			8.87	14.79	17.75	20.70	
115.5		1.00	6.97		11.61	13.94	16.26		
		1.33	7.57		12.62	15.14	17.66		
127.5		1.00	6.07		10.13	12.16	14.18		
		1.33	6.46		10.77	12.93	15.08		
139.5		1.00	5.29		8.82	10.59	12.35		
		1.33	5.55		9.25	11.10	12.95		

Table 5. Post Compression capacities

Where:

- b width (depth) of end-post/stud, in.
- C_D load duration factor
- l_e effective length of compression member, in.
- $P_{c\perp}$ maximum design capacity in compression perpendicular to grain (load duration factor C_D not applicable)
- $P_{c\parallel}$ maximum design capacity in compression parallel to grain, with effective length of member = l_e
- t thickness (breadth) of end-post/stud, in. (length of bolt in the end-post)

Shear wall sheathing must be adequately nailed to compression members to transfer the story compression forces. Additional members required

due to accumulation of compressive load from above need not be nailed to the structural sheathing. Often times, studs can be added adjacent to boundary posts to make up the additional required compressive capacity required due to shear walls above.

DETAILING

There are three basic types of continuous tie-rod systems currently in-use:

1. Bearing type systems
2. Shear bolt type systems
3. Hybrid systems, which combine either bearing type or bolt type systems together with floor to floor straps.

1. Bearing type of system consists of a continuous standard or high strength threaded rod or high-strength cable coupled with a steel plate. The steel plate is installed either at the sill plate above the shear wall being held down, or to a bridge block at or near the mid-height of studs on the shear wall being held down. Figure 1A shows the typical configuration and installation for a bearing type of system. An example of the load path for this system is shown in Figure 7a.

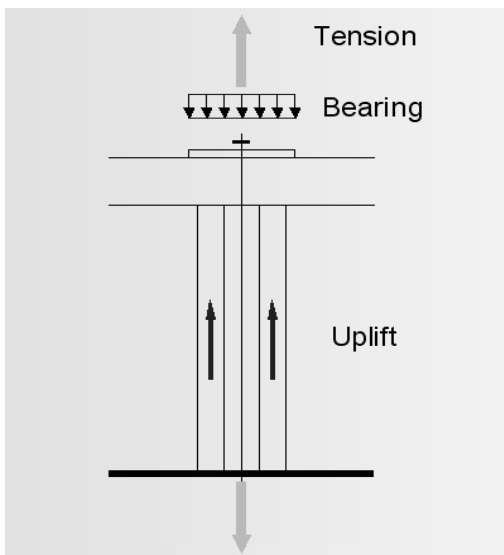
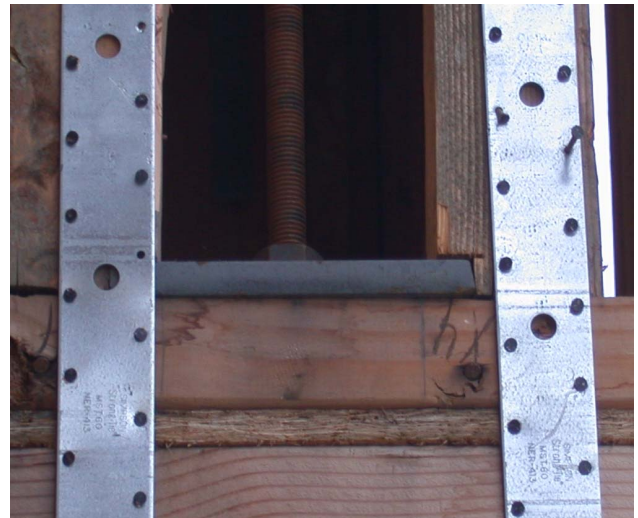

Figure 7a. Bearing plate system load path.

Key detailing points are: (1) when using the bridge block method of terminating the rod and plate washer, the studs below the bridge block at the termination point must be adequately connected to the full height end-posts in the shear wall, and (2) the use of a bearing plate requires that the manufacturer select a plate a plate that satisfies bearing

perpendicular to the grain of wood, bending in the steel plate, and shear in the steel plate. If the resulting bearing plate length exceeds the manufacturer's standard clear distance between end posts then this distance may be increased by the manufacturer which results in a different position for the continuous rod and an increased moment arm (distance between tension rod/cable and compression end posts) for overturning calculations.

Alternatively, if the standard distance between end-posts remains fixed, the engineer and contractor must be conscientious of the fact that the resulting plate length may necessitate the plate being installed underneath the end-posts in some situations (this situation occurs most often in the hybrid system). For ease of construction, this situation should be avoided. Refer to Picture 3. For stacking shear walls, the space between end-posts should be determined at the lowest level (highest load) and kept a constant at all levels of the building.



Picture 3. Bearing plate length resulting in bearing plate below end-posts (avoid for ease of construction).

2. Bolted type of system consists of a continuous standard or high strength threaded rod coupled with fabricated steel connectors, which are bolted to end-posts in the shear wall being held down. Bolted systems should consider the capacity of the bolts in the end-posts, the tension capacity at the net section of the end-posts, the capacity of the steel connector, and the capacity the rod. Figure 1B shows the typical configuration and installation for a bolted type of system. An example of the load path for this system is shown in Figure 7b.

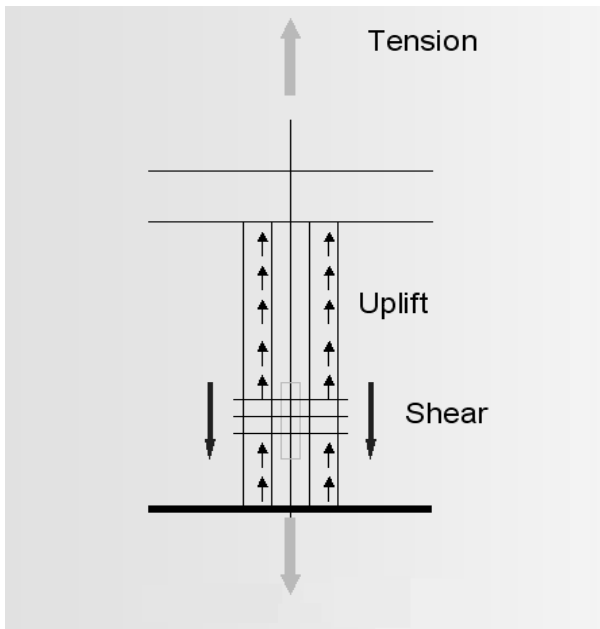

Figure 7b. Shear bolted system load path.

Key detailing points are: (1) ensuring the correct end distance from end-post ends to bolts, and (2) using the net section of the end-post to calculate allowable tension loads (3) ensuring bolt holes are not over drilled beyond the code maximum 1/16 inch.

3. Hybrid type of system combines either one of the first two systems with floor to floor straps at the upper levels, typically in the range of 18 gauge to 12 gauge. An example of the load path for this system is shown in Figure 7c.

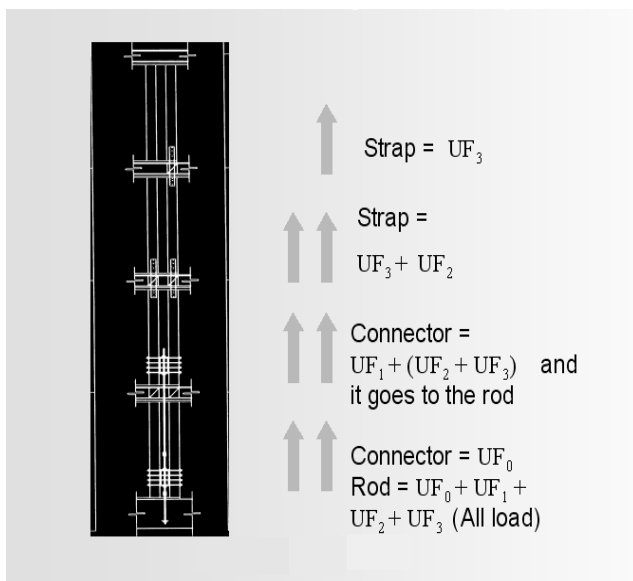

Figure 7c. Hybrid system load path.

When these straps are installed over the structural sheathing, boundary nailing in the sheathing should

be omitted so as to not perforate the sheathing too much. The strap nailing will provide adequate attachment of the sheathing to the end-posts. Figure 8c shows the typical configuration and installation for a hybrid type system. In this type of system, the use of continuous tie-rods is eliminated at a level where the loads no longer necessitate a tie-rod system. The load path is slightly different since the tension loads at the upper levels accumulate onto end-posts rather than a tie-rod. Unlike the completely continuous tie-rod system, in a hybrid system, the bearing plate or shear connector device installed at the highest elevation must be capable of resisting the tension load on the level of installation plus all the tension loads above that level.

Tension loads can be transferred to the double end-posts of the continuous tie-rod system below the strapped level with strap(s) at each of the double end-posts or studs at the strapped level. As an alternate, a single end-post or stud at the strapped level can be strapped to one of the double end-posts or studs of the continuous tie-down system. Both end-posts of continuous tie systems must have boundary nailing. The boundary nails of the single continuous tie down system end-post receiving the strap must have the capacity to resist the uplift force at that level plus the force from the strap. This will assure an equal distribution to both end-posts.

Since shrinkage compensating devices cannot be installed at strapped levels, shrinkage effects must be considered and included in shear wall deflection equations. It is advisable to attach straps as late as possible in the construction sequence in order to allow preliminary settling to occur and to allow the lumber to reach equilibrium moisture content. Specifying a lower lumber moisture content at time of strap installation can also help alleviate shrinkage problems.

Figure 8 shows the load accumulation on four story tie-down runs for several various configurations of hold down installations.

DRAWINGS

Structural Drawings.

Tie-down system specification on structural drawings may be done in one of the two following recommended formats.

1 Specify a particular manufacturer and the specific components for the tie-rod system, using standard catalog callouts or available engineering software and/or drawings from the manufacturer.

2 Specify the accumulated uplift force at each level on the design documents. With this option, the drawings must specify the necessary performance criteria for the installed tie-down system.

The minimum parameters necessary to specify the performance criteria for the tie-down system are: (1) the individual uplift loads at each level which the system must carry, (2) displacement limits for elements of the tie-down system at the specified uplift loads, (3) whether or not connections must be made at every floor or if floors can be skipped (some manufacturers and engineers have differing opinions about “skipping floors” or not providing restraints at each level), (4) whether or not shrinkage compensating devices are required. These items can typically be specified in schedules, as shown in Table 6.

Minimum end-post sizes must also be made a part of the schedule since the end-post size is typically determined by the compressive demand resulting

from the appropriate load combination $D + L + E/1.4$ (for ASD design). Take note that this resulting load will be somewhat higher than the tension load determined by the load combination $0.9D - E/1.4$. If levels are allowed to be skipped, the compressive load on end-posts (due to E) will accumulate to the level, which is restrained. The tension loads on connectors (bearing plates or bolts) will accumulate to the highest connected level. Header or beam loads must also be considered. Refer to Figure 8.

Shop Drawings

It is recommended that tie-down shop drawings be prepared much the same as for roof trusses, steel fabrication, or other pre-manufactured systems. If the tie-down shop drawings mandate engineering work in the selection the tie-down rod sizes, plate washers, and bolted connections, they must be stamped and signed by a licensed Civil or Structural Engineer. Additionally, these shop drawings must be reviewed and approved by the general contractor, engineer of record, and the governing building department prior to fabrication or installation.

SAMPLE HOLD DOWN SCHEDULE					
LEVEL \ SYMBOL		◊	◊	◊	◊
4th FL.	LOAD	2K	2K	4K	4K
	MIN. POST	2X	2X	2-2X	2-2X
3rd FL.	LOAD	4K	6K	7K	7K
	MIN. POST	2-2X	4X	2-3X	2-3X
2nd FL.	LOAD	7K	7K	7K	24K
	MIN. POST	2-3X	2-3X	2-3X	2-6X4
1st FL.	LOAD	12K	19K	24K	38K
	MIN. POST	2-4X	2-4X6	2-4X6	2-6X6

NOTES:

1. ◊ DENOTES HOLD DOWN AND MINIMUM POST(S) PER SCHEDULE.
2. LOADS LISTED ARE ASD LEVEL ACCUMULATED UPLIFT LOADS.
3. TIEDOWN SYSTEM ELONGATIONS SHALL BE LIMITED TO 1/8" PER FLOOR.
4. FOR THIS PROJECT, A CONNECTION SHALL BE MADE AT EACH LEVEL.
5. SHRINKAGE COMPENSATION DEVICES SHALL BE INCLUDED WITH THE TIEDOWN SYSTEM.

Table 6. Structural drawing specification for tie-down system.

Structural Observation

While the construction industry gains experience in the installation of these hold down systems, it is desirable to have the engineer of record observe at least a sampling of the installations to ensure proper use. To guaranty this, the engineer of record may specify that Structural Observation is required in accordance with *UBC§1702 and IBC§1702*. This

structural observation does not replace any inspections by the governing jurisdiction. Nor is the contractor relieved from his duty to correctly install the system if the EOR has “approved” the installation. Observations are to verify that the builder is building in general conformance with the plans, (i.e.-boundary nailing, shrinkage compensation, load transfer devices, compression posts and other general installation requirements).

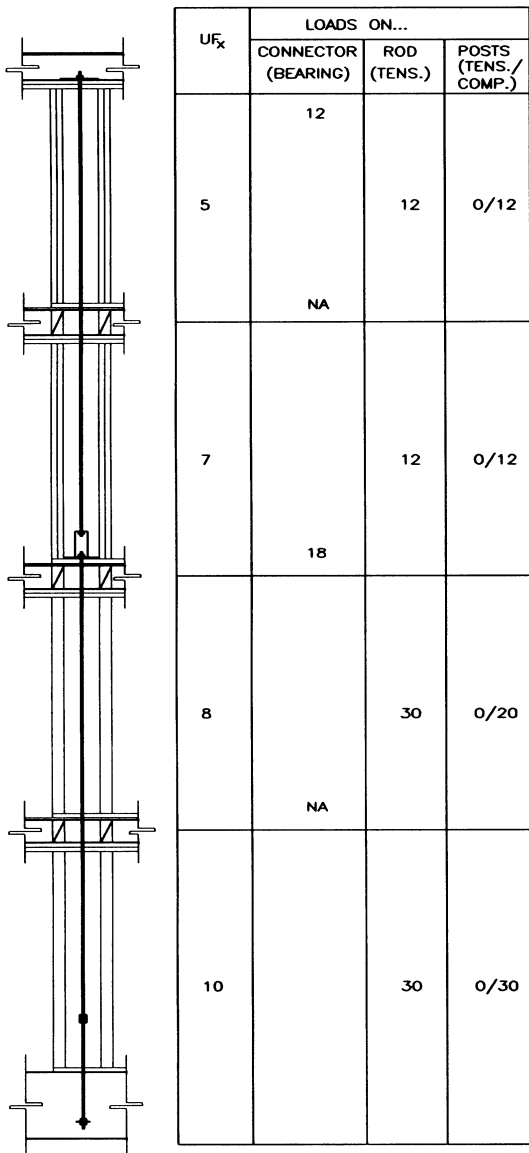

Figure 8(a1)

Bearing plate system skipping level

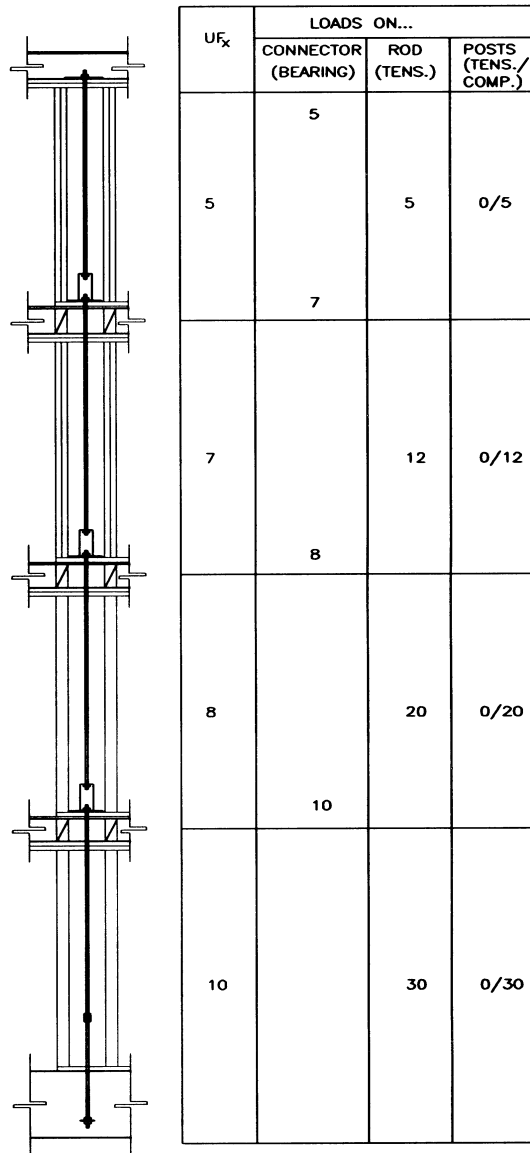

Figure 8(a2)

Bearing plate system

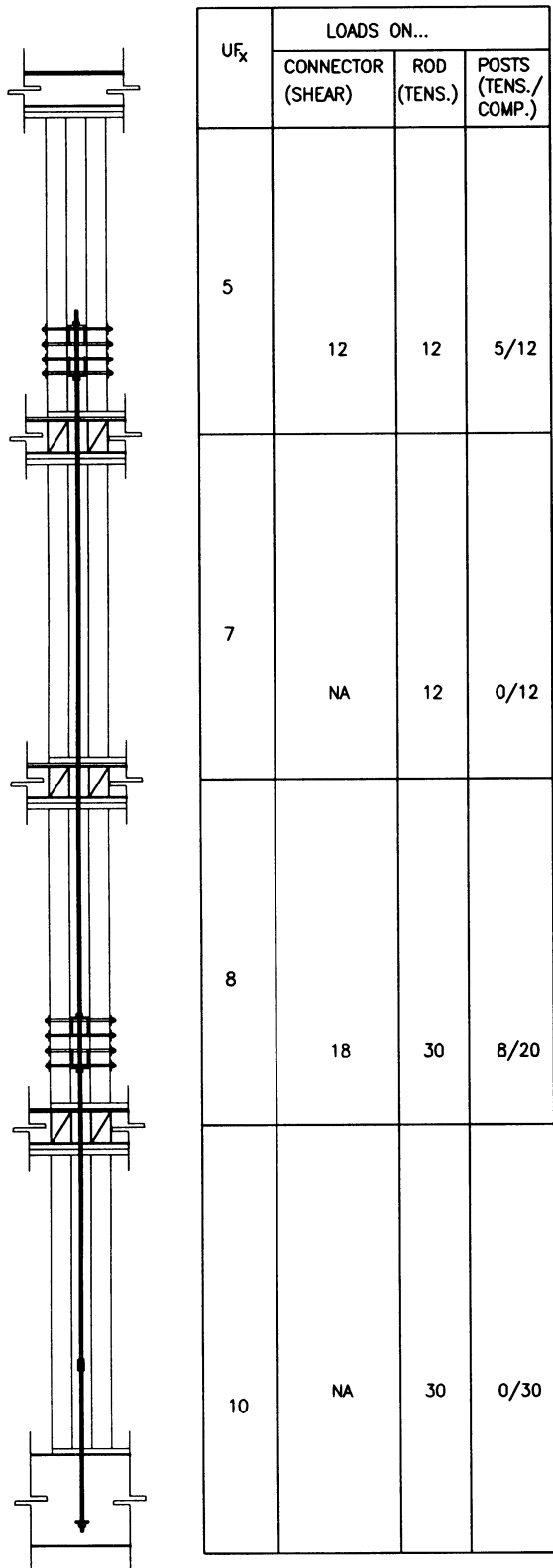

Figure 8(b1)

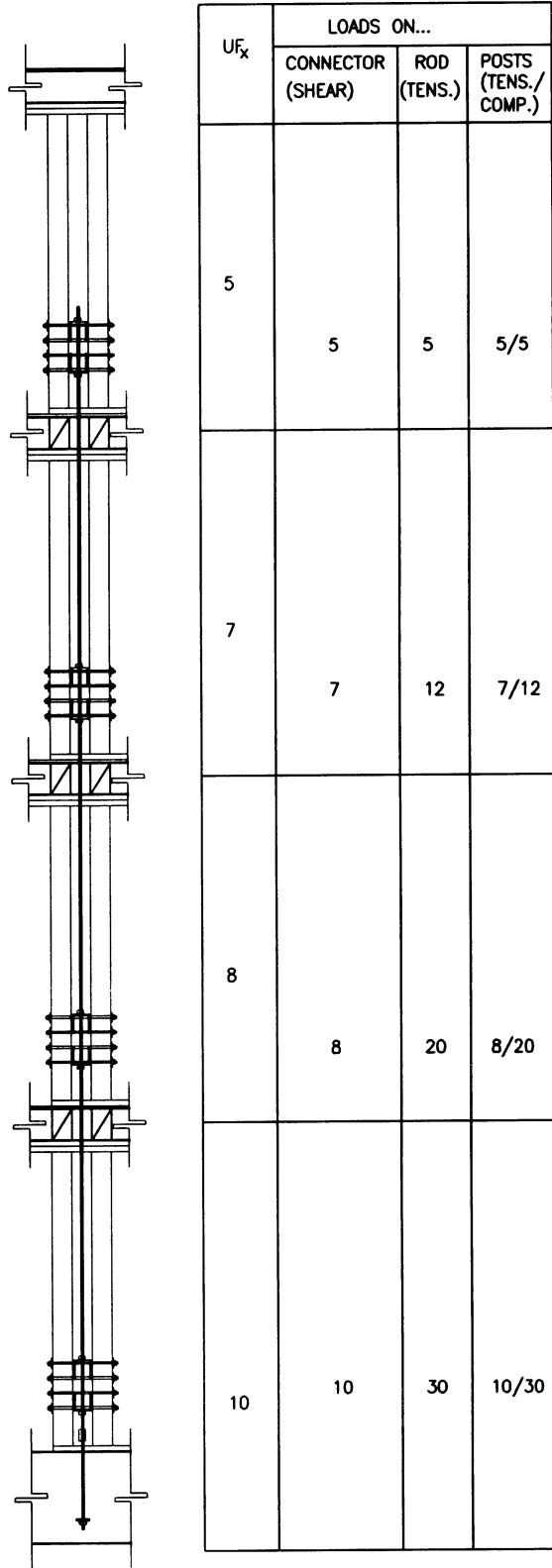

Figure 8(b2)

Bolted hold-down devices skipping floors

Bolted hold-down devices at all levels

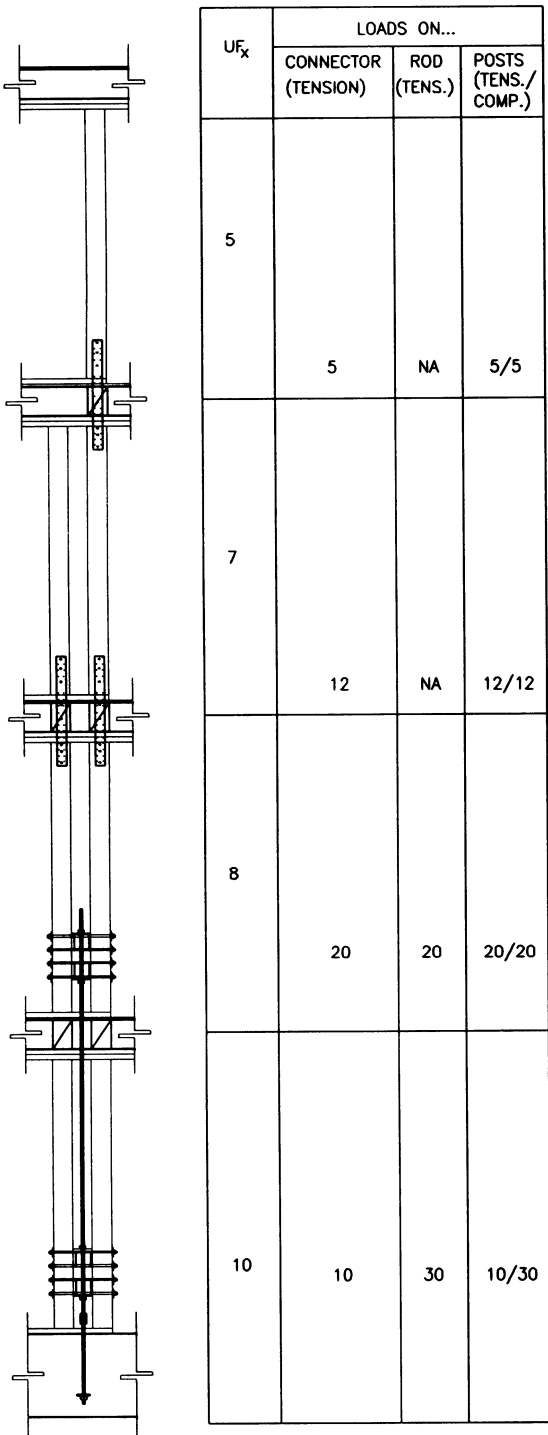

Figure 8(c)

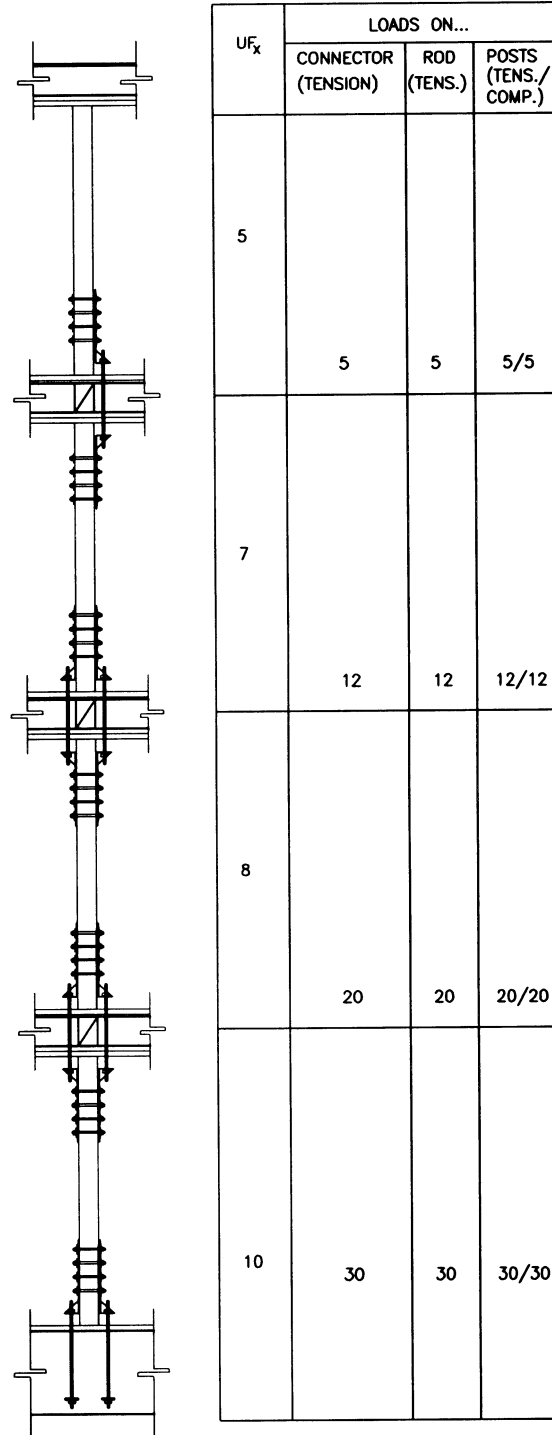

Figure 8(d)

Hybrid system with devices at all levels

Conventional hold-downs

Summary

Continuous tie-down systems provide an economical and structurally sound method of resisting overturning in multiple story wood framed buildings.

To design/specify a continuous tie-down system the design engineer must:

- Distribute lateral load to resisting elements using a rational method which considers the rigidity of the diaphragms and resisting elements.
- Determine individual/accumulated uplift forces at each level
- Specify the tie-down system
 1. Select a particular manufactured system and its components or
 2. Provide accumulated uplift loads at each level
- Determine or specify tie-down system contribution to shear wall deflection due to
 1. Tie-down rod/cable elongation
 2. Tie-down transfer device deflection
 3. Oversized bolt holes for concentric bolted connectors
- Determine deformation due to sill and top plate crushing from compression perpendicular to grain
- Determine shrinkage
- Specify if shrinkage devices are required
- Specify if transfer/restraint device may skip levels
- Check end-posts:
 1. For tension on net section
 2. For compression parallel to grain (include header, beam, etc. loads)
 3. For crushing of sill plates for compression perpendicular to grain
 4. Specify minimum end-post sizes

REFERENCES

International Code Council, 2000 Edition,
International Building Code, Falls Church, VA

American Forrest & Paper Association, 1997 Edition,
National Design Specification for Wood Construction, Washington, DC

International Conference of Building Officials, 1997 Edition, *Uniform Building Code*, Whittier, CA

Ronald P. Gallagher, Robert Clark, David A. Hutchinson, Jon P. Kiland, John W. Lawson, Joseph R. Maffei, Douglas S. Thompson and Theodore C. Zutty, April 2000, *Seismic Design Manual*, Vol. II, pp. 11- 159, Structural Engineers Association of California, Whittier, CA