

## Accommodating Building Deflections

What every EOR should know about accommodating deflections in secondary cold-formed steel systems

Schafer, B.W. (Chair\*)  
DiGirolamo, E.  
Eiler, M.  
Fisher, J.  
Lindenberg, R.

Madsen, R.L.  
Mettler, M.  
Miller, T.H.  
Peyton, D.  
Polard, G.

Roecker, T.  
Rogers, C.  
Shanmugam, N.E.  
Walker, S.H.

*\* The authors of this article are all members of the ASCE-SEI Committee on Cold-Formed Steel*

### **Foreword:**

*The ASCE-SEI Committee on Cold-Formed Steel is charged to “disseminate and interpret information on the behavior and design of structural steel members, cold-formed to shape from flat materials...” The committee consists of both practitioners and educators and over the last several years the focus of the committee’s ongoing discussions has been on deflections in cold-formed steel systems. The opinion of the committee is that a variety of issues related to deflections in secondary cold-formed steel systems are poorly understood by key parties involved in building construction. This lack of understanding negatively impacts building performance as well as initial cost, and operating cost. Further, current conditions indicate these issues are of growing, rather than of lessening, importance. Therefore, the committee set out to provide a brief article of interest to the Engineer of Record (EOR), who may subcontract out secondary cold-formed steel (CFS) systems, on problems, ramifications and hopefully some solutions and guidance when dealing with how CFS systems should be designed to properly accommodate building deflections: both vertical deflections and lateral drifts. The phrase - secondary cold-formed steel system - is used here to describe cold-formed structural members that support exterior finishes, but are not considered part of the primary structural frame. These cold-formed members may support a variety of exterior finishes: metal panels, exterior insulation and finish systems (EIFS), concrete masonry units (CMU), brick etc. The committee’s focus is on accommodating the primary building movements, i.e., in-plane lateral and vertical deflections, thus the selection of L/whatever limits for out-of-plane deflections of CFS systems supporting masonry, EIFS, etc. are not discussed (instead see, e.g, Fisher and West 1990).*

As the Engineer of Record (EOR) your responsibilities run far and wide. Your primary concern is the structural frame, so for many, when it comes time to worry about the building’s exterior skin, very little detail is provided. Instead a phrase goes into the contract documents such as “Design of curtainwall and metal stud framing shall be the responsibility of the contractor and shall meet the requirements of this Specification and all applicable Building Codes.” This division of labor between the EOR and a specialty sub-contractor is common for secondary cold-formed steel wall systems and has typically been beneficial for both the EOR and the sub-contractor. However, as the primary caretaker of the building, the EOR needs to understand the ramifications of design decisions on both performance and cost with respect to secondary systems.

Indications are that the need for an EOR to understand the ramifications of their design on secondary systems will dramatically increase, not decrease, in the future. Performance-based design is the next generation of design specifications in the United States (SEAOC 1995, FEMA 2000). At least two heavyweights lurking in the background are indirectly motivating the

movement to performance-based design: government and insurance. The mitigation of extreme events (earthquake, wind, snow) is costly both for the government (e.g., FEMA) and insurance companies. Therefore, in the future, building codes will go beyond simple “life safety” and prescribe different performance objectives for the building: operational, immediate occupancy, life safe, near collapse; under different load (event) scenarios: frequent, design level, maximum/ultimate level. Specifications with this philosophy have already been developed (FEMA 2000) and more are sure to be forthcoming as major research effort is being expended in this direction (e.g., through the NSF funded earthquake research centers). If you think this is just a problem in “Earthquake Country” then you’re missing the point. Designing for minor and moderate damage events means that you are no longer designing for the “big one” all the time. The big earthquake, the big wind, and the big snow are still important, but now the more commonly occurring earthquake, wind, snow, etc. are just as important in your design.

In some regards performance-based design is not the sea of change that it first appears to be, after all, successful design of the structural frame already demands that you provide (1) ultimate strength “life safety” and provide (2) serviceability (control of deflections, vibrations and the like) for “operational” conditions. For minor and moderate events you ensure (with a certain level of confidence) that the structural frame will incur no damage. **It is here, where we get back to our primary point: for your well designed frame, the cost of damage in minor events will occur in your secondary framing systems. In fact, the majority of costs for all but the “big one” are primarily related to the ability, or lack thereof, of your secondary system to accommodate deflections of your structural frame. Adequately specifying and accommodating both lateral and vertical building deformations becomes a key component in the cost vs. risk equation for minor and moderate damage events.** Engineers are typically accustomed to considering the importance of load path in their structure, an excellent concept for understanding strength issues. When deflections govern design a “movement path” for those deflections must be understood and monitored with the same diligence as the load path.

Let us begin with accommodating vertical building deflections. Building codes (e.g., UBC) provide guidance on vertical deflections of the primary structural frame and the EOR also is typically aware of unique vertical deflection issues such as creep in the primary framing material or large stiffness changes in the primary framing between floors. Unfortunately, the awareness of Architects, much less builders, in accommodating these deflections is quite low. For example, a common problem is the simple horizontal control joint. Typically Architects abhor the large horizontal seam introduced into the building’s appearance by horizontal joints. Unfortunately, in the common case of a slip track below each floor, so that the studs start and stop at each floor, the cladding on the wall cannot run continuously across the floors! With the exterior continuity the load path will follow stiffness and primarily go through the studs which were probably not designed to support significant axial loads. In addition, the movement path is going to be a clear problem for the cladding. Problematic deformation is likely to result from poorly thought out (but commonly occurring) details such as this. Communication between the EOR and the Architect at the earliest possible stage on the need to properly accommodate vertical deflection of the primary frame is crucial to successful performance.

Not all details in current practice for CFS systems accommodate vertical deflections. Arguments about “screw movement” to accommodate deflections may be fine for small buildings or where anticipated vertical deflections are small, but are quickly problematic for significant vertical movement. Is it enough for the conscientious EOR to prescribe slip clips to accommodate the vertical deflections? Not in general. Here communication between the EOR and the cold-formed steel system subcontractor is critical. At a minimum, if the EOR is prescribing slip clips,

anticipated floor-to-floor movement should be discussed; however, more importantly, the EOR should be aware that industry-standard “slip clips” do not exist and many of the products are proprietary. (See Fig. 2 for further discussion on “slip” clips.) In this case, the experience of the CFS sub-contractor can help communicate the cost/risk scenario of the possible details: from simple friction-held clips that trap one flange to more robust solutions. The design of the CFS system cannot be isolated from the design of the primary structure, and review of wall sections and details is essential in order to ensure adequate intended movement paths. If this is not done, and instead these details are left to the builder they may either: (1) not be incorporated - leading to a future problem or (2) a builder may raise the initial estimate due to uncertainty about a potentially problematic connection detail.

Problems with vertical deflections are minor compared to those with accommodating lateral building deflections. Here, disconnect between the involved parties (EOR, CFS subcontractor, Architect, and Builder) is the greatest. Currently this disconnect is felt most strongly on the West Coast as codes (e.g., UBC 1997) generally require (1) larger drift demands and (2) prescribe the performance of the secondary CFS systems. For example, under extreme events deflection demands are as high as 2.5% of the story height, and although secondary systems supporting exterior finishes may be damaged, the finish (e.g. masonry) should not fall off the building during the event. As discussed previously, future building codes are likely to put more emphasis on accommodating lateral deflections, not less.

In the rush to get contract documents out to bid it is likely that the EOR may choose to be relatively vague about the lateral deflection requirements. This situation is likely to result in one of the following: (1) increased operating costs due to a finished building that does not have an adequate movement path and will thus incur significant damage when even minor lateral deflections are imposed; (2) increased initial cost due to the uncertainty introduced into the bid process as reflected by bids placed by the Builders; or (3) increased construction costs, added as costly design changes are made during the construction process to accommodate the lateral movements.

Fully accommodating lateral drifts can be a costly endeavor. An EOR needs to assign building drifts based on the actual building stiffness and an understanding of the cost vs. risk tradeoffs that occur in accommodating lateral deflections in secondary systems. *You should be aware that accommodating large lateral deflections in CFS wall systems can be an endeavor that adds significant costs to traditional systems.*

Five details are selected to illustrate the points being made about accommodating vertical and lateral building deflections: rigid detail, slotted “slip” clip detail, slotted track detail, single deflection track detail, and a double deflection track detail. **The provided details are not “standard” details and are not meant to be used as such. The details are for illustrative purposes only. The provided costs are subjective estimates for comparison purposes based on the experience of the members of the committee. Connection costs can vary significantly.** All of the details shown are appropriate in certain situations. Standardization of testing and performance of many of these details does not currently exist. It is not the committee’s intent to provide an opinion on the definitive detail to use for accommodating deflection; rather it is our goal to provide guidance on the cost vs. risk ramifications of a representative sample of the types of connections in current use.

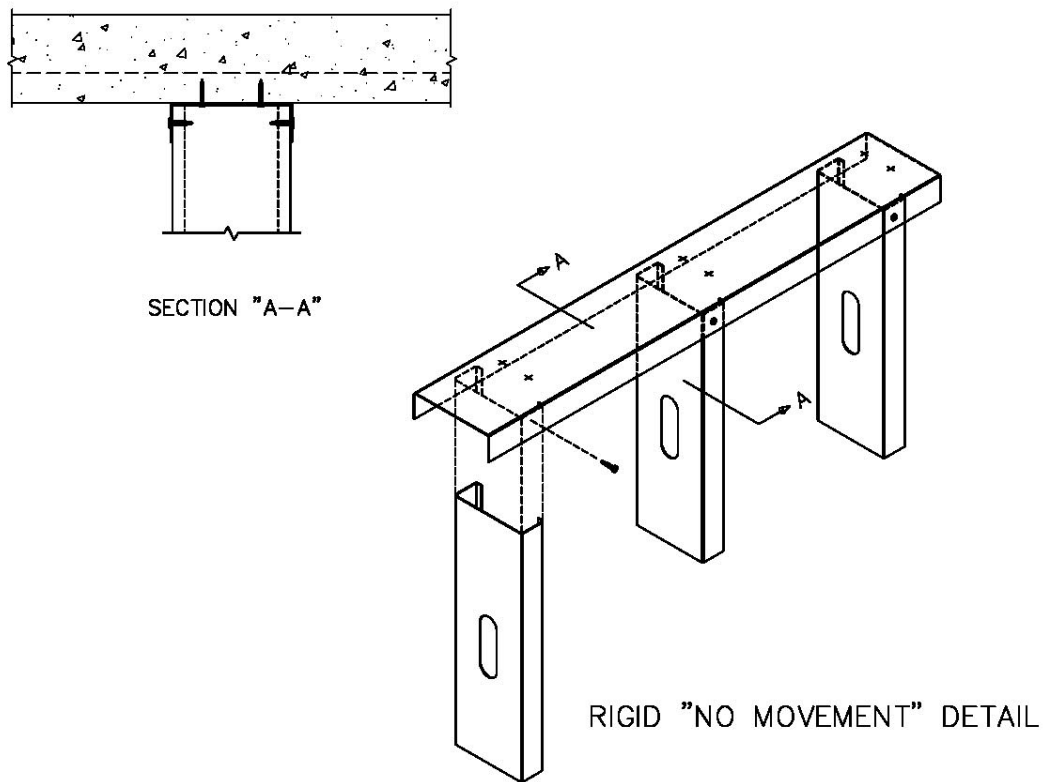

**Fig. 1**

**Cost:**

\$ Approximately \$18/LF → cost ratio\* ~ 1.0

**Description:**

All elements are screwed together as shown.

**Advantages:**

Inexpensive and easy to construct, no specialized components or details required.

**Disadvantages:**

No movement path for accommodating vertical or lateral deflection exists.

**Load Path /Movement Path:**

This connection will bring the load path into the secondary framing system. If the wall can take the load this may be an adequate situation in low load and deformation situations. There is no movement path available, and the entire secondary system will be engaged if deformations are imposed. In such a situation the secondary wall system is not really secondary, it is integral with the primary system and should be treated as such in design. This is a complicated endeavor because neither definitive guidance on the stiffness of this system, nor the amount of racking that the system can withstand before losing all or part of the exterior finish is available.

**Comment:**

Though the drawbacks of such a detail are obvious, it still may be found in current practice. Although a fine connection for load bearing systems with small deflections, for secondary systems it is a potential problem for the performance of the wall and may even negatively impact the performance of the primary system in some cases.

\* Prices vary greatly, cost ratios for all connections are based on comparison to the rigid “no movement” detail shown here. There are many unknowns that cannot be taken into account (e.g., type of proprietary products) but assuming stud/track size and gauge are the same for each condition then comparisons across connections should be valid. Also note, slab edge conditions may have a major effect on the total installed cost (this is considered separately, where appropriate).

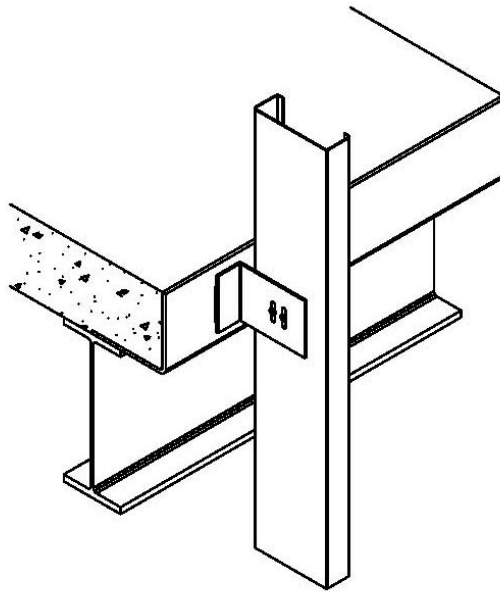

SLOTTED OR "SLIP" CLIP DETAIL

Fig. 2

**Cost:**

\$ - \$\$\$ typical cost ratio\* ~ 1.3, additional cost of slab edge angle brings the total cost ratio for the illustrated system to 2.3. ("Slip" clip systems that accommodate both lateral and vertical deflections also exist, but are not shown here. Costs of such systems vary but a typical cost ratio would be 1.7 alone, or 2.7 with the slab edge angle included.)

**Description:**

A special slotted (often proprietary) clip is used to connect the stud to track as shown.

**Advantages:**

Provides for vertical deformation at clip location; allows for offset of stud and structure (e.g. edge of slab) to provide straight, plumb walls

**Disadvantages:**

No accommodation of lateral deformations

**Load Path/Movement Path:**

For vertical deformation the movement in the clip allows the load path to avoid the stud and thus ensure the secondary nature of the CFS system. However, under lateral demands the clip will engage the wall, some slip may occur, but under moderate or large lateral demands the secondary wall system will be in the load path for lateral movement. This potentially changes the lateral stiffness of the primary system and increases the forces in the secondary system.

**Comment:**

Details of this kind are common, with many different varieties available. Successfully employed, the detail ensures that under gravity loads the wall is "non load bearing" however, under lateral demands the wall system will be engaged in a manner similar to the rigid detail. Adequate performance anticipated when vertical deformation is of primary concern, problematic otherwise.

\*Costs can vary particularly widely for this connection detail, therefore contact manufacturers.

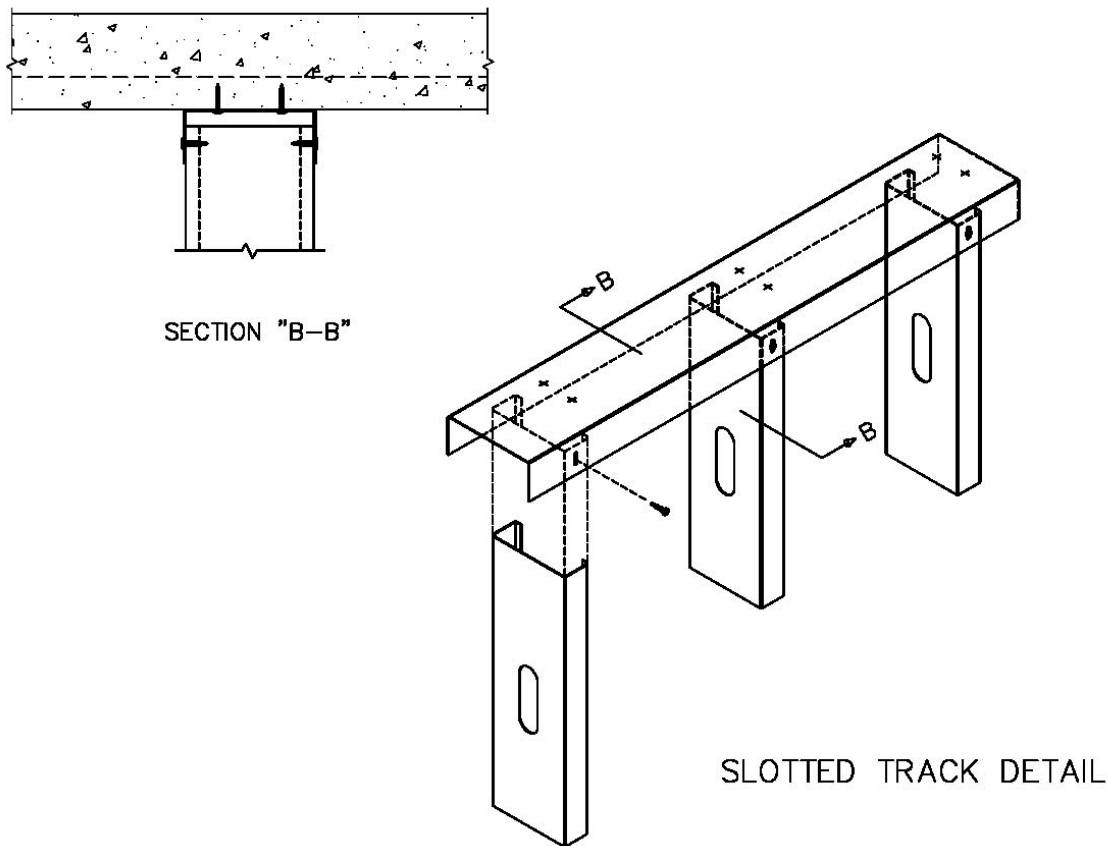

Fig. 3

**Cost:**

\$ - \$\$ typical cost ratio ~ 1.1

**Description:**

The top track is provided with slotted holes to allow vertical deformation.

**Advantages:**

Relatively inexpensive, provides for vertical movement of the structure; restrains the top of studs from rotation.

**Disadvantages:**

Accommodation of lateral deformations requires special connections to the structure above.

**Performance:**

Adequate when vertical deformation is of primary concern, problematic otherwise.

**Load Path/Movement Path:**

For vertical deformation the slot in the track allows the load path to avoid the stud and thus insure the secondary nature of the CFS system. However, under lateral demands some slip may occur, but under moderate or large lateral demands the secondary wall system will be engaged and in the load path unless specially detailed connections to the structure are provided. If no such special details are provided, the lateral stiffness of the primary system and the forces in the secondary system may be impacted.

**Comment:**

Successfully employed, this detail ensures that the stud is “non load bearing” under gravity load. For light lateral demands this may be sufficient, but for moderate to large lateral demands the wall will be engaged in the same manner as the rigid detail unless special connections to the structure are provided.

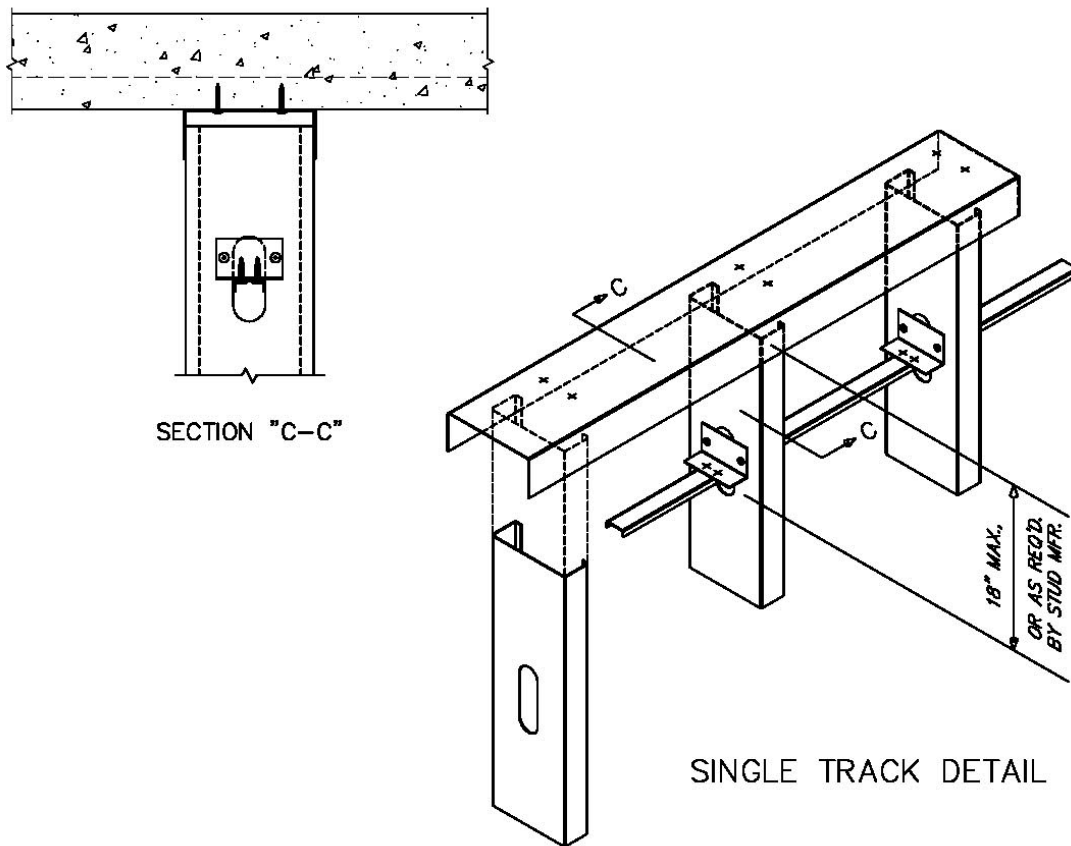

Fig. 4

**Cost:**

\$ - \$\$ typical cost ratio ~ 1.1

**Description:**

Studs are cut short and held by friction into the top track. (An alternative to the illustrated bridging detail, sometimes found in current practice, is to provide flat strap blocking one face.)

**Advantages:**

Potential to accommodate vertical and moderate lateral movement. Relatively inexpensive.

**Disadvantages:**

Strength is limited by plate bending in the track leg. *The potential of the studs and track to disengage entirely under large lateral displacements exists.* Additional rotational restraint is required near the top of the studs.

**Load Path/Movement Path:**

The fact that the studs and track are not interconnected allows for positive vertical and lateral movement of the system.

**Comment:**

This detail is commonly used, particularly for interior partition framing. It is very easy to install and requires only 'standard' parts. Great care must be taken in designing and detailing this type of connection to ensure proper engagement of the studs at all times and to determine the required thickness of the track to prevent plate bending failure. Friction connection creates a type of stick-slip connection – loads are transferred up to a point and then movement will occur as detail slides. Performance depends on amount of force required to allow sliding, how sliding is controlled, etc.

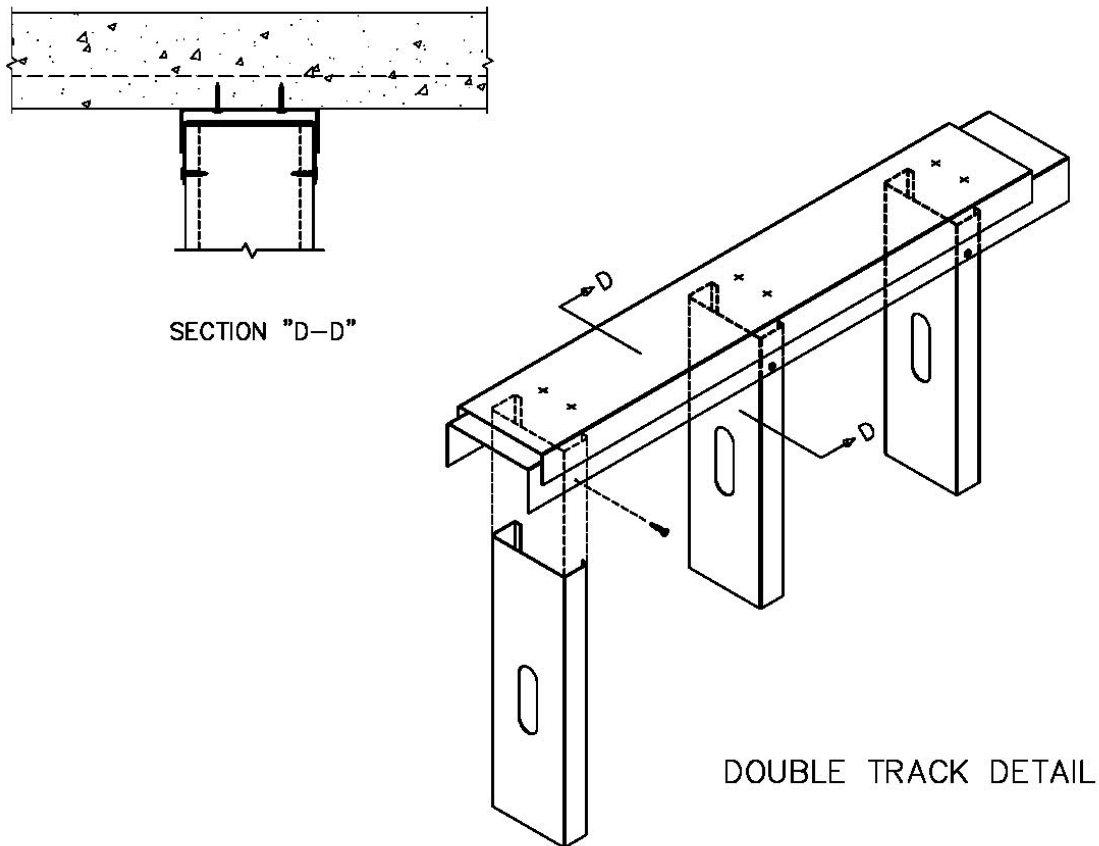

**Fig. 5**

**Cost:**

**\$ - \$\$** typical cost ratio ~ 1.20

**Description:**

Separate tracks are used to connect to the top of the wall and to the next floor and then held together by friction.

**Advantages:**

Provides clear lateral and vertical isolation of the secondary CFS wall. Provides rotational restraint at the top of the studs missing in the single track detail.

**Disadvantages:**

Can be expensive, and difficult to install. Can cause distortion in the finish due to 'build-up' of the steel components. Lateral deformations become problematic at corners or on irregular or curved walls. Note, that for large deflection demands the possibility of separation of the two tracks (and therefore disengagement of the wall) does exist.

**Load Path /Movement Path:**

Since there is no positive attachment between the two tracks both vertical and lateral building deformations are well-accommodated.

**Comment:**

This relatively costly detail is an example of a means of disconnecting or isolating the secondary CFS system from the primary systems. Large deformations of the wall may occur and this must be considered when considering interactions of the wall system, at corners, or any other location, for instance interior partitions that are not moving with the primary system.

A special type of stud framing is the spandrel-supported system. It commonly occurs when ribbon or strip window bands interrupt the vertical studs. If there is no mechanism to support gravity loads and span between columns, the stud framing and exterior finish materials must rely on floor slabs and perimeter beams to provide both wind load and gravity load support. Such a framing system is shown in Figure 6. Spandrel framing deflection issues are unique and are beyond the scope of this article. Suffice it to say for our purposes that the types of exterior cladding materials and window system selected are key considerations. The cladding and window suppliers should be consulted to ensure that the systems are compatible with each other and with the framing system. Stud framing will be required to support the weight of the ribbon windows above as well as the cladding attached to the face of the studs. Differential floor live load deflection must be accommodated at the interface of the windows and the exterior finish materials. Proper detailing of window/cladding interface is critical to properly accommodate deflection for this type of framing system.

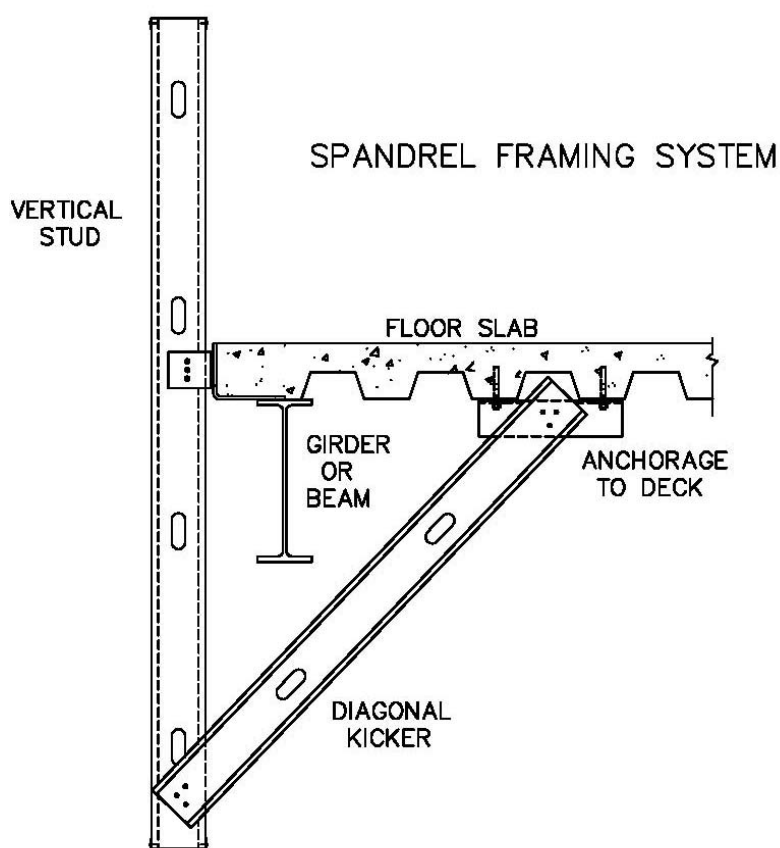

**Fig. 6**

Hopefully the discussion of the details and their estimated costs provides some preliminary means to weigh the cost to risk ramifications for accommodating vertical and lateral deflections in a building. Unfortunately, at this time, the process is by no means fine-tuned nor overly quantitative. Although we may speak of moderate demands or large demands these numbers are not quantified. As the EOR it is important that you realize many questions still remain for accommodating vertical and lateral deflections. The answers to these questions influence the decisions that you and your CFS sub-contractor might make.

When must vertical deflection be explicitly accounted for? A rigid detail may perform fine, even for a non-load bearing wall, if the difference in stiffness between the secondary and primary systems is large enough that the load path remains in the primary system; but where is the limit to this notion? How stiff must the primary system be? If the demands are small enough that the non-load bearing secondary wall could bear the load then a rigid detail may be sufficient. Otherwise it generally seems prudent to provide for vertical movement in all non-load bearing secondary CFS walls.

When are the lateral deformation demands large enough that they must be explicitly addressed? No definitive guidance currently exists. Some rules of thumb may be used, (e.g., 1/16<sup>th</sup> of an inch) but they certainly are open to debate. However, little is available to replace them at this point. It is clear that 2.5% of the story height is a large lateral demand and must be considered, but what about 0.5%? Should this automatically require an expensive double-track detail such as the one given in the examples? Definitive experimental data does not exist and both the EOR and the CFS sub-contractor must apply their best judgment in this case.

In addition to knowing when the deformation demands are large enough that movement must be considered other difficult questions remain: How much racking can a cold-formed system sustain without losing all or part of the finish elements? What is the stiffness of a CFS wall system with different details and finishes? Our lack of knowledge of these systems promotes the concept of disconnecting the primary and secondary systems under moderate and large events if damage is to be minimized. Of course, this is a costly decision and is thus not always done.

It is clear that there is much work to be done in developing secondary CFS systems, but good details exist. A conscientious designer who is considering load path and movement path for both the primary and secondary systems will find they will be able to insure a better performing and lower cost building if these considerations are made early in the project and communicated explicitly to the Architect and Builder.

#### **References:**

SEAOC (1995). "Vision 2000, Performance based seismic engineering of buildings, vols I and II: Conceptual Framework." Structural Engineers Association of California (SEAOC).

Fisher, J., West, M. (1990). "Serviceability Design Considerations for Low-Rise Buildings." AISC Steel Design Guide Series (3).

FEMA (2000). Recommended Seismic Design Criteria for New Steel Moment-Frame Buildings, Federal Emergency Management Agency (FEMA) No. 350.